

User Manual

Power Controllers DPU Series

TCD210144AB

Thank you for purchasing an Autonics product :

This user manual contains information about the product and its proper use,
and should be kept in a place where it will be easy to access

Preface

Thank you for purchasing Autonics product.





Please familiarize yourself with the information contained in the Safety Considerations section before using this product.

This user manual contains information about the product and its proper use, and should be kept in a place where it will be easy to access.

User Manual Guide

- Please familiarize yourself with the information in this manual before using the product.
- This manual provides detailed information on the product's features. It does not offer any guarantee concerning matters beyond the scope of this manual.
- This manual may not be edited or reproduced in either part or whole without permission.
- A user manual is not provided as part of the product package.
- Visit our web site (www.autonics.com) to download a copy.
- The manual's content may vary depending on changes to the product's software and other unforeseen developments within Autonics, and is subject to change without prior notice. Upgrade notice is provided through out Autonics web site.
- We contrived to describe this manual more easily and correctly. However, if there are any corrections or questions, please notify us these on Autonics web site.

User Manual Symbols

Symbol	Description
 Note	Supplementary information for a particular feature.
 Warning	Failure to follow instructions can result in serious injury or death.
 Caution	Failure to follow instructions can lead to a minor injury or product damage.
 Ex.	An example of the concerned feature's use.
※1	Annotation mark.

Safety Considerations

- Following these safety considerations will ensure the safe and proper use of the product and help prevent accidents and minimize hazards.
- Safety considerations are categorized as Warnings and Cautions, as defined below:

 Warning	Warning	Cases that may cause serious injury or fatal accident if instructions are not followed.
--	----------------	---

 Caution	Caution	Cases that may cause minor injury or product damage if instructions are not followed.
--	----------------	---

Warning

- Fail-safe device must be installed when using the unit with machinery that may cause serious injury or substantial economic loss. (e.g. nuclear power control, medical equipment, ships, vehicles, railways, aircraft, combustion apparatus, safety equipment, crime/disaster prevention devices, etc.)
Failure to follow this instruction may result in personal injury, economic loss or fire.
- Do not use the unit in the place where flammable/explosive/corrosive gas, high humidity, direct sunlight, radiant heat, vibration, impact, or salinity may be present.
Failure to follow this instruction may result in explosion or fire.
- Install on a device panel, and ground separately.
Failure to follow this instruction may result in fire or electric shock.
- Do not connect, repair, or inspect the unit while connected to a power source.
Failure to follow this instruction may result in fire or electric shock.
- Do not disassemble or modify the unit.
Failure to follow this instruction may result in fire or electric shock.
- Check 'Connections' before wiring.
Failure to follow this instruction may result in fire.

Caution

- Use the unit within the rated specifications.
Failure to follow this instruction may result in fire or product damage.
- Use a dry cloth to clean the unit, and do not use water or organic solvent.
Failure to follow this instruction may result in fire or electric shock.
- Keep the product away from metal chip, dust, and wire residue which flow into the unit.
Failure to follow this instruction may result in fire or product damage.
- Since leakage current still flows right after turning off the power or in the output OFF status, do not touch the load terminal.
Failure to follow this instruction may result in electric shock.
- Since leakage current still flows right after turning off the power or in the output OFF status, do not touch the load terminal.
Failure to follow this instruction may result in electric shock.

The specifications, dimensions, etc are subject to change without notice.

Be sure to follow cautions written in the instruction manual, user manual and the technical descriptions (catalog, homepage).

Table of Contents

Preface	iii
User Manual Guide	iv
User Manual Symbols.....	v
Safety Considerations.....	vi
Table of Contents	vii
Table of Contents	viii
1. Product Introduction	11
1.1 Features.....	11
1.2 Ordering information	12
1.3 Unit description	13
2. Specifications	15
4. Connections.....	22
4.1 Single-phase (DPU1 series).....	22
4.2 3-phase (DPU3 series).....	24
5. Installation and Initial Operation	26
5.1 Installation.....	26
5.2 Initial display	26
5.3 Parameter setting group	26
5.3.1 Parameters.....	26
5.3.2 Monitoring Mode	27
5.3.3 Operation Mode [OP].....	28
5.3.4 Setting Mode 1 [St-1].....	29
5.3.5 Setting Mode 2 [St-2].....	30
6. Parameter Setting and Functions	32
6.1 Control input	32
6.2 Functions	33
6.2.1 Control method [C-nd].....	33
6.2.2 Soft start [St-t].....	36
6.2.3 Start limit [S-Ln] and start limit time [S-Lt]	37
6.2.4 Output slope setting [SLOP].....	37
6.2.5 Output slope manual adjustment [R-GR].....	38
6.2.6 Base-up [b-UP]	38

Table of Contents

6.2.7	Slow up/Slow down [$UP-L/dn-L$]	39
6.2.8	Output high limit value [$H-OL$], Output low limit value [$L-OL$]	39
6.2.9	Digital input (DI)	40
6.2.10	Proportional and integral constant set of feedback control	42
6.2.11	Input correction [i_{n-b}]	43
6.2.12	Input slope correction [$SPRn$]	43
6.2.13	Display value content [$diSP$], bar graph content [bar]	43
6.2.14	Load resistance display method [$drES$]	44
6.2.15	Full load auto recognition [$F-Ld$]	45
6.2.16	Parameter lock [$L-OL$]	45
6.3	Alarm	46
6.3.1	Overcurrent alarm [$OC-R$]	46
6.3.2	Current limit [$C-Ln$]	46
6.3.3	Overvoltage alarm [$OV-R$]	47
6.3.4	Fuse disconnection alarm [$FUSE$]	47
6.3.5	Heatsink overheating alarm [$HEAT$]	47
6.3.6	Element error alarm [SCR]	47
6.3.7	Heater disconnection alarm [$Hb-R$]	48
7.	Factory Default	50
8.	Maintenance	52
8.1	Fuse	52
8.1.1	Single-phase (DPU1 series)	52
8.1.2	3-phase (DPU3 series)	53
8.2	Thyristor (SCR)	53
9.	Modbus Mapping Table	54
9.1	Function code 3 (0×03) = Read holding registers	54
9.2	Function code 4 (0×04) = Read input registers	54
9.3	Function code 6 (0×06) = Write single registers	55
9.4	Function code 16 (0×10) = Write multiple registers	55
9.5	Address mapping table	56
9.5.1	Input registers	56
9.5.2	Holding registers	58

1. Product Introduction

1.1 Features

- High speed and high accuracy by digital control using high speed CPU
- Various controls
 - Phase control, feedback control (constant voltage/constant current/constant power)
 - Zero crossing cycle control (fixed/variable cycles)
 - Zero crossing ON/OFF control
- Improved maintainability with built-in fast-acting fuse and easy fuse replacement
- Communication output model: RS485 (Modbus RTU)
- Various control inputs and DI inputs
 - control input: analog (current, voltage), ON/OFF (voltage pulse, no voltage), communication (RS485), potentiometer
 - DI input: AUTO/MAN switching, RUN/STOP switching, Reset, output holding, SP designation (6 setting points can be customized)
- Various alarm output
 - Overcurrent, overvoltage, fuse break, heat sink overheat, device fault, heater break alarm (partial heater break detection)
- Improved convenience by separating operation part
- Applicable load
 - Supercantal, platinum, molybdenum, carbon, halogen lamps, chrome, nickel, etc.

1.2 Ordering information

DPU	1	2	A	—	025	R																																			
						Option	<table border="1"> <tr> <td>R</td> <td>RS485 communication</td> </tr> <tr> <td>D</td> <td>Remote Display Unit</td> </tr> <tr> <td>A</td> <td>Remote Display Unit + RS485 communication</td> </tr> <tr> <td>N</td> <td>No option</td> </tr> </table>	R	RS485 communication	D	Remote Display Unit	A	Remote Display Unit + RS485 communication	N	No option																										
R	RS485 communication																																								
D	Remote Display Unit																																								
A	Remote Display Unit + RS485 communication																																								
N	No option																																								
					Rated current capacity		<table border="1"> <tr> <td>025</td> <td>25A</td> <td>200</td> <td>200A</td> </tr> <tr> <td>040</td> <td>40A</td> <td>250</td> <td>250A</td> </tr> <tr> <td>050</td> <td>50A</td> <td>350</td> <td>350A</td> </tr> <tr> <td>070</td> <td>70A</td> <td>400</td> <td>400A</td> </tr> <tr> <td>080</td> <td>80A</td> <td>500</td> <td>500A</td> </tr> <tr> <td>100</td> <td>100A</td> <td>600</td> <td>600A</td> </tr> <tr> <td>120</td> <td>120A</td> <td colspan="2" rowspan="4" style="text-align: center;">/</td> </tr> <tr> <td>150</td> <td>150A</td> </tr> <tr> <td>180</td> <td>180A</td> </tr> <tr> <td></td> <td></td> </tr> </table>	025	25A	200	200A	040	40A	250	250A	050	50A	350	350A	070	70A	400	400A	080	80A	500	500A	100	100A	600	600A	120	120A	/		150	150A	180	180A		
025	25A	200	200A																																						
040	40A	250	250A																																						
050	50A	350	350A																																						
070	70A	400	400A																																						
080	80A	500	500A																																						
100	100A	600	600A																																						
120	120A	/																																							
150	150A																																								
180	180A																																								
			Size				<table border="1"> <tr> <td></td> <td>Single-phase</td> <td>3-phase</td> </tr> <tr> <td>A</td> <td>0 to 70A</td> <td>0 to 50A</td> </tr> <tr> <td>B</td> <td>80 to 200A</td> <td>70 to 200A</td> </tr> <tr> <td>C</td> <td colspan="2">250 to 350A</td> </tr> <tr> <td>D</td> <td colspan="2">400 to 600A</td> </tr> <tr> <td>E</td> <td colspan="2">Option</td> </tr> </table>		Single-phase	3-phase	A	0 to 70A	0 to 50A	B	80 to 200A	70 to 200A	C	250 to 350A		D	400 to 600A		E	Option																	
	Single-phase	3-phase																																							
A	0 to 70A	0 to 50A																																							
B	80 to 200A	70 to 200A																																							
C	250 to 350A																																								
D	400 to 600A																																								
E	Option																																								
			Power supply				<table border="1"> <tr> <td>1</td> <td>110VAC</td> </tr> <tr> <td>2</td> <td>220VAC</td> </tr> <tr> <td>3</td> <td>380VAC</td> </tr> <tr> <td>4</td> <td>440VAC</td> </tr> </table>	1	110VAC	2	220VAC	3	380VAC	4	440VAC																										
1	110VAC																																								
2	220VAC																																								
3	380VAC																																								
4	440VAC																																								
			Control phase				<table border="1"> <tr> <td>1</td> <td>Single-phase</td> </tr> <tr> <td>3</td> <td>3-phase</td> </tr> </table>	1	Single-phase	3	3-phase																														
1	Single-phase																																								
3	3-phase																																								
			Item				<table border="1"> <tr> <td>DPU</td> <td>Digital Power Controller Unit</td> </tr> </table>	DPU	Digital Power Controller Unit																																
DPU	Digital Power Controller Unit																																								

1.3 Unit description

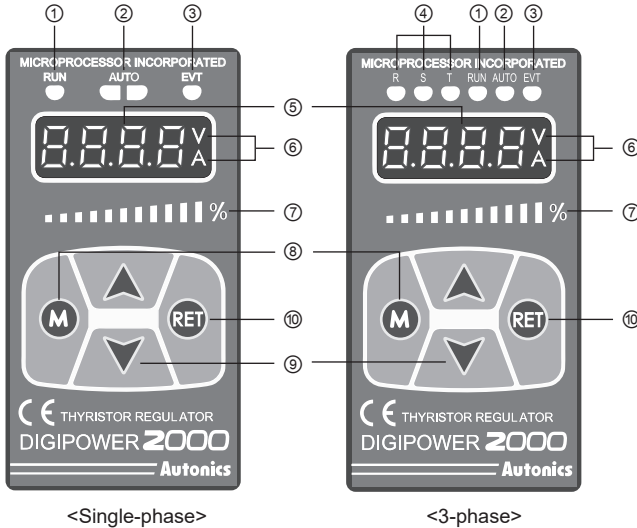

- ① RUN indicator: Turns ON in RUN, turns OFF in STOP.
- ② AUTO indicator: Turns ON in AUTO, turns OFF in MANUAL.
- ③ EVT indicator: Turns ON in Digital Input (DI-1 to 3) ON, flashes in alarm output.
- ④ R, S, T lamp: Turns ON differently by displayed value in display part.
E.g.) When R, S lamps turn ON, it displays voltage between R-S line
- ⑤ Display part: Displays selected display value content in RUN mode, displays parameter and set value in SET mode.
- ⑥ V, A indicators: The V indicator turns ON when displaying voltage.
The A indicator turns ON when displaying current.
The V, A indicators turn ON when displaying power.
The V, A indicators turn OFF when displays resistance and input value.
- ⑦ Bar display: Turns ON as 0 to 100% ratio for selected display value.
- ⑧ **M** key: Used to enter parameter mode, monitoring mode and to move between parameters.
- ⑨ **▲**, **▼** key: Used to move setting modes and to set parameters.
- ⑩ **RET** key: Used to return to RUN mode from SET mode

2. Specifications

Series	DPU1		DPU3	
Control phase	Single-phase		3-phase	
Power supply	110VAC~/220VAC~/380VAC~/440VAC~ (FAN and control power 220VAC~ 50/60Hz separately)			
Allowable voltage	90 to 110% of rated voltage		85 to 115% of rated voltage	
Rated frequency	50/60Hz (auto recognition), allowable frequency range: ± 2 Hz			
Min. load current	1A			
Output range	Phase control: 0 to 98%, Z.C. control: 0 to 100%			
Control method ^{※1}	<ul style="list-style-type: none"> • Phase control <ul style="list-style-type: none"> : Normal control (Non-Feedback), constant voltage/constant current/constant power control (Feedback) • Cycle control (Z.C.): Fixed cycle control, variable cycle control • ON/OFF control (Z.C.) 			
Load	<ul style="list-style-type: none"> • Phase control: resistance load, inductive load • ON/OFF, Cycle control: resistance load 			
Power consumption	Max. 7W (except FAN operation power)		Max. 10W (except FAN operation power)	
Display method	<ul style="list-style-type: none"> • Display value and SV display <ul style="list-style-type: none"> : 7-segment 4 digit • Status display: 4 LED • Display value percentage display: 11 LED Bar 		<ul style="list-style-type: none"> • Display value and SV display <ul style="list-style-type: none"> : 7-segment 4 digit • Status display: 6 LED • Display value percentage display: 11 LED Bar 	
Output accuracy	<ul style="list-style-type: none"> • Constant voltage feedback control <ul style="list-style-type: none"> : Within $\pm 3\%$ F.S. of rated voltage (within variable $\pm 10\%$ F.S. of rated voltage) • Constant current feedback control <ul style="list-style-type: none"> : Within $\pm 3\%$ F.S. of rated voltage (within variable 1 to 10 times of rated resistance) • Constant power feedback control <ul style="list-style-type: none"> : Within $\pm 3\%$ F.S. of rated voltage (within variable $\pm 10\%$ F.S. of rated voltage and within variable 1 to 10 times of rated resistance) • Normal control: within $\pm 10\%$ F.S. of rated voltage 			
Set method	By front keys, by communication			
Control input	<ul style="list-style-type: none"> • Auto: 4-20mA / 0-20mA / 0-5VDC$\overline{=}$ / 1-5VDC$\overline{=}$ / 0-10VDC$\overline{=}$ / voltage pulse(0/12VDC$\overline{=}$(24VDC$\overline{=}$)) / no-voltage input (ON/OFF) / communication input(RS485) • Manual: inside 10kΩ adjuster, outside 3 to 10kΩ adjuster (min. 2W) 			
Digital input(DI)	AUTO/MAN switching, RUN/STOP switching, RESET, Output holding, SP setting (SP1 to 6)			
Display content	Control input, load voltage, load current, load power, load resistance, power supply frequency			
Min. display output	Min. 2.5% of rated voltage/current			
Option output	RS485 communication output (Modbus RTU method), [max. 32 units]			
Dielectric strength	2,000VAC 50/60 Hz for 1 min (between input terminal and power terminal)			
Vibration	0.75mm amplitude at frequency of 5 to 55Hz (for 1 min) in each of X, Y, Z directions for 2 hours			
Insulation resistance	Over 200M Ω (at 500VDC megger)			
Noise immunity	± 2 kV the square wave noise (pulse width 1 μ s) by the noise simulator			
Environment	Ambient temp.	-10 to 50°C, storage: -20 to 80°C		
	Ambient humi.	5 to 90%RH, storage: 5 to 90%RH		
Approval	CE			
Weight ^{※2}	<ul style="list-style-type: none"> • A size <ul style="list-style-type: none"> : Approx. 3.2kg (approx. 3.0kg) • C size <ul style="list-style-type: none"> : Approx. 12.1kg (approx. 11.0kg) 	<ul style="list-style-type: none"> • B size <ul style="list-style-type: none"> : Approx. 5.6kg (approx. 3.0kg) • D size <ul style="list-style-type: none"> : Approx. 19.3kg (approx. 11.0kg) 	<ul style="list-style-type: none"> • A size <ul style="list-style-type: none"> : Approx. 7.6kg (approx. 6.5kg) • C size <ul style="list-style-type: none"> : Approx. 21.1kg (approx. 20.0kg) 	<ul style="list-style-type: none"> • B size <ul style="list-style-type: none"> : Approx. 13.0kg (approx. 11.5kg) • Approx. size <ul style="list-style-type: none"> : Approx. 35.7kg (approx. 30.8kg)

※1. Variable cycle control is only for single-phase model.

※2. The weight includes packaging. The weight in parenthesis is for unit only.

※Environment resistance is rated at no freezing or condensation.

Communication specifications

Protocol	Modbus RTU
Connection type	RS485
Application standard	Compliance with EIA RS485
Max. connection	32 units (address: 01 to 64)
Synchronization method	Asynchronous
Communication method	2-wire half duplex
Communication distance	Max. 800m
Communication speed	4800, 9600, 19200, 38400bps
Communication response wait time	5 to 99ms
Data bit	8-bit (fixed)
Parity bit	Even (fixed)
Stop bit	1-bit (fixed)

3. Dimensions

(unit: mm)

3.1 Single-phase(DPU1 Series)

(1) A Size: DPU1□A-025 / 040 / 050 / 070

※25A, 40A, 50A are not attached a fan.

※1. Rated current capacity 70 A model: 263

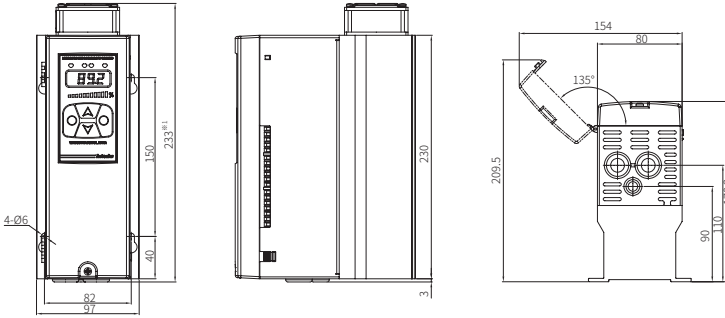

(2) B Size: DPU1□B - 080 / 100 / 120 / 150 / 180 / 200

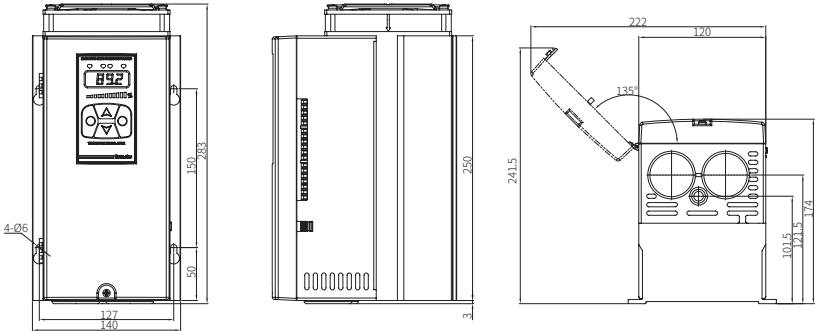

(3) C Size: DPU1□C - 250 / 350

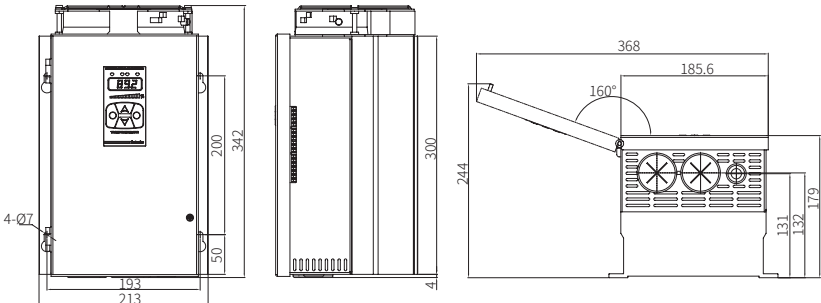

(4) D Size: DPU1□D - 400 / 500 / 600

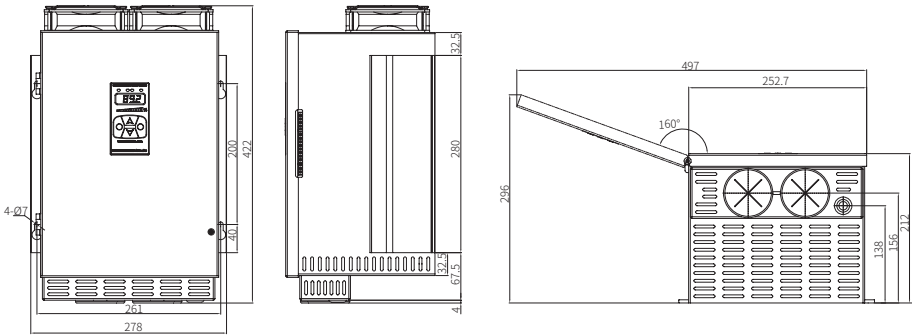

3.2 3-phase (DPU3 Series)

(1) A Size: DPU3□A - 025 / 040 / 050

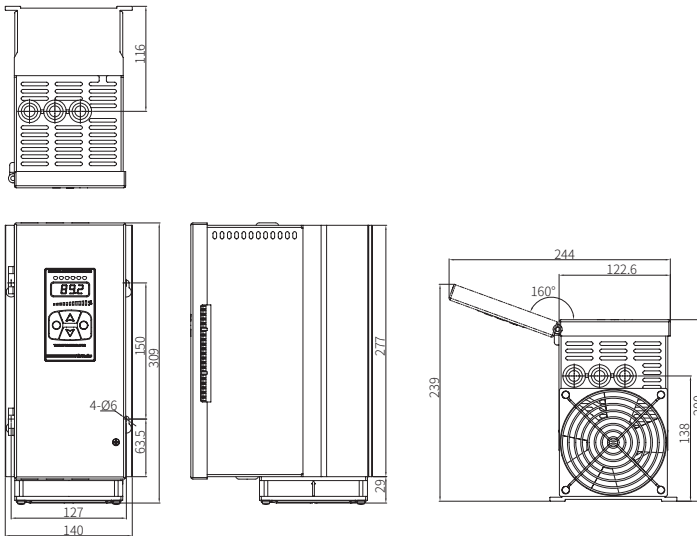

(2) B Size: DPU3 B - 070 / 080 / 100 / 120 / 150 / 180 / 200

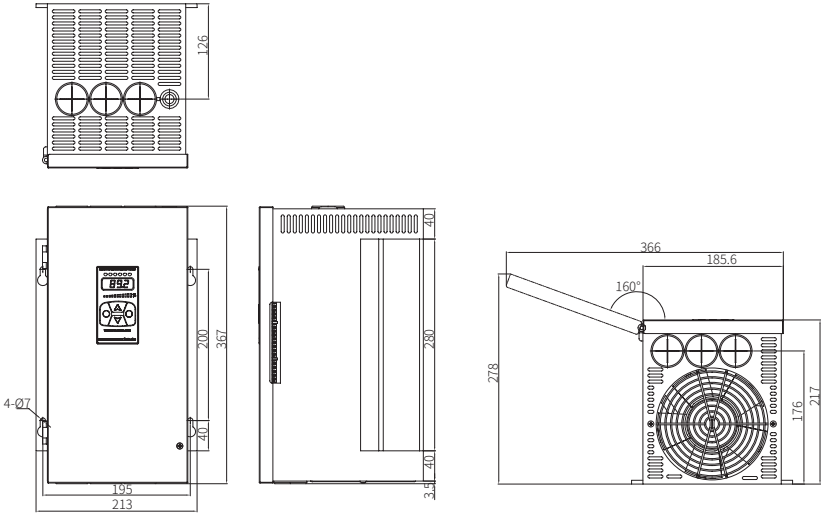

(3) C Size: DPU3 C - 250 / 350

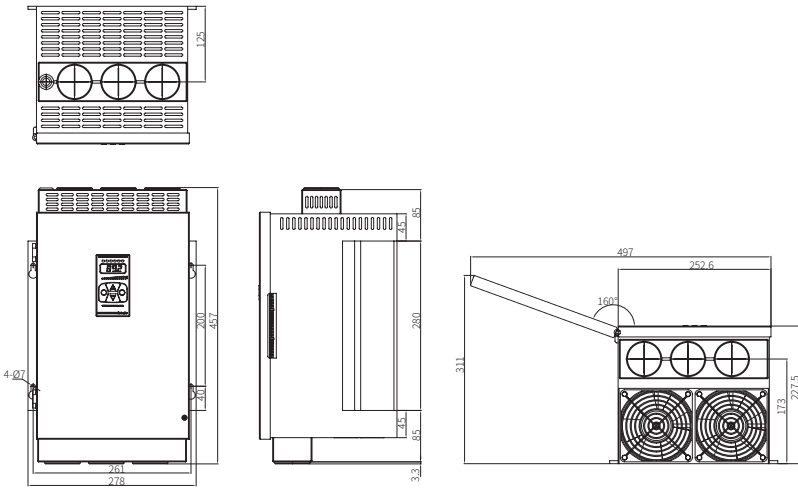

(4) D Size: DPU3□D - 400 / 500 / 600

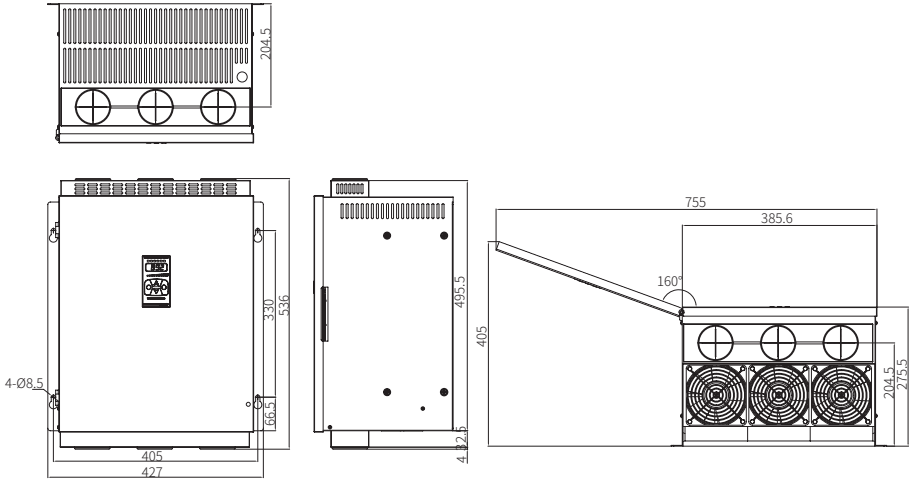



Note

Remote display unit

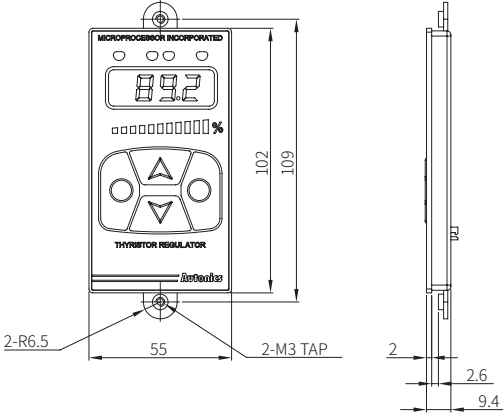

Remote display plate

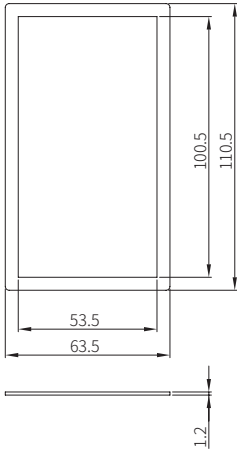

Remote display panel cut-out

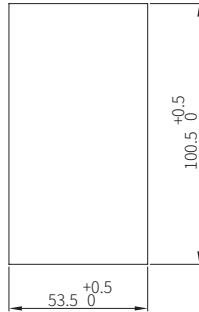

※ It is recommended for remote panel cable to use max. 5 m to prevent noise. (Check the length when ordering it.)

4. Connections

4.1 Single-phase (DPU1 series)

• A Size

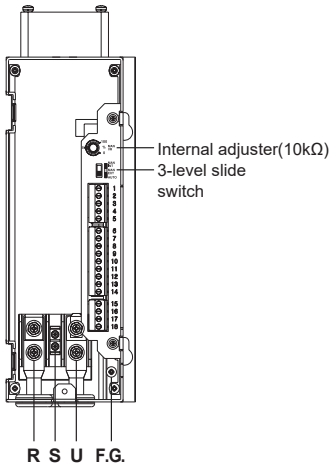

• B Size

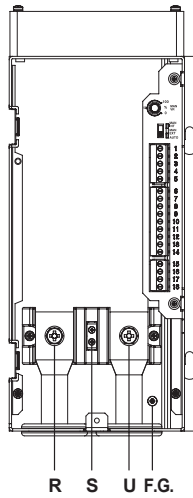

• C Size

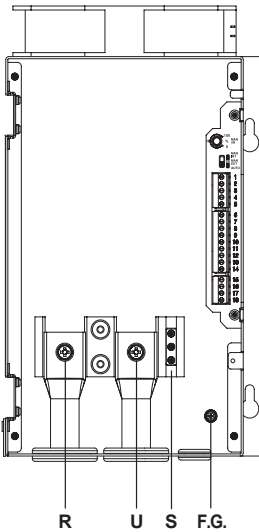

• D Size

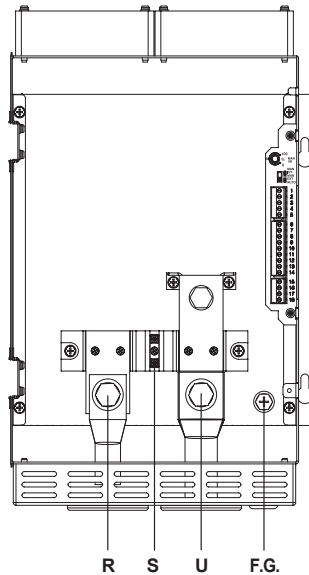

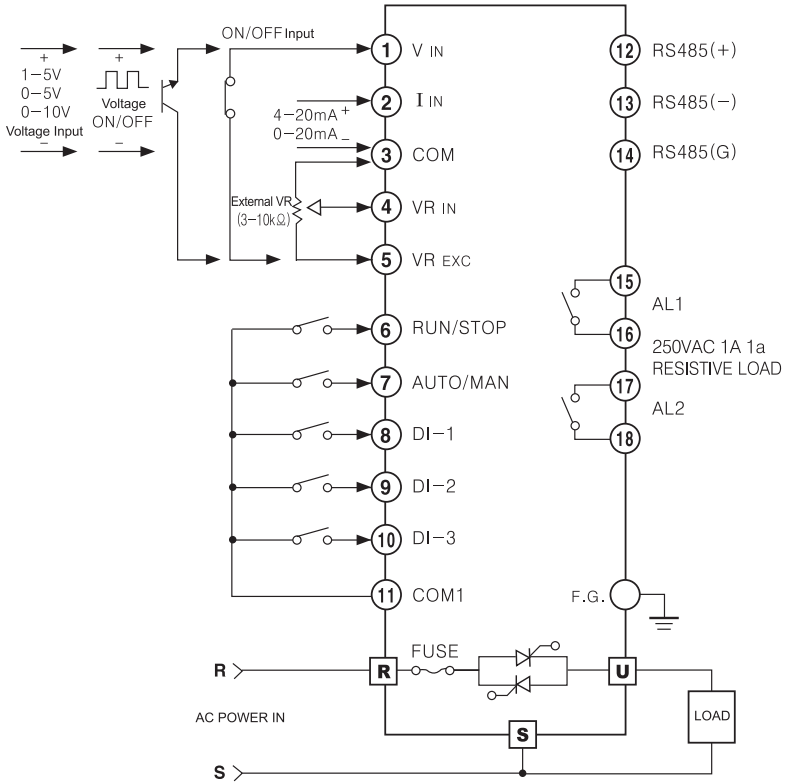

- ※1. Do not mix noise to input cable.
It is recommended to use shield cable, twisted cable as input cable for effective noise.
- ※2. If there is possible to affect inductive noise, it is recommended to use shielded cable at high-frequency power for effective noise.
- ※3. DI input switch should be for low current and ON resistance should be max. 20Ω (including cable resistance).
- ※4. DI input terminals are COM, DI-1 to 3, RUN, AUTO.
- ※5. For remote display unit option model, use connection cable as our standard cable.
- ※6. When connecting ⑥, ⑩, it operates as MANUAL. When connecting, ⑥, ⑦, ⑩, it operates AUTO.

4.2 3-phase (DPU3 series)

• A Size

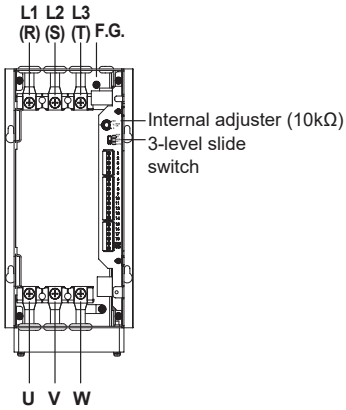

• B Size

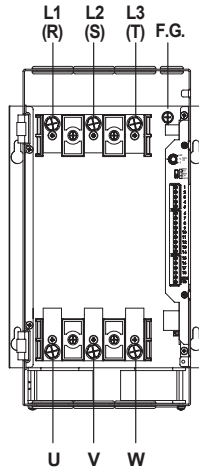

• C Size

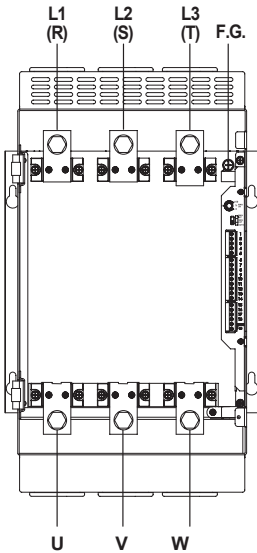

• D Size

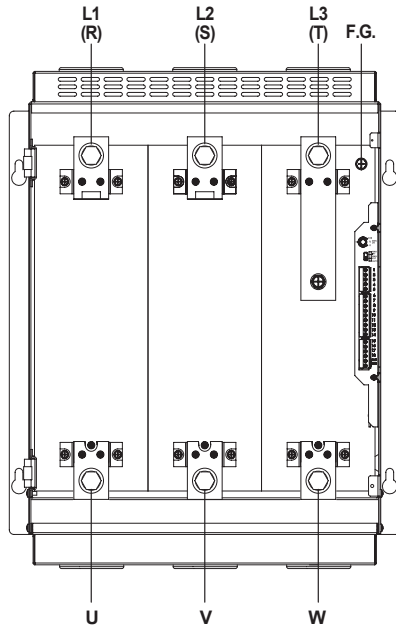

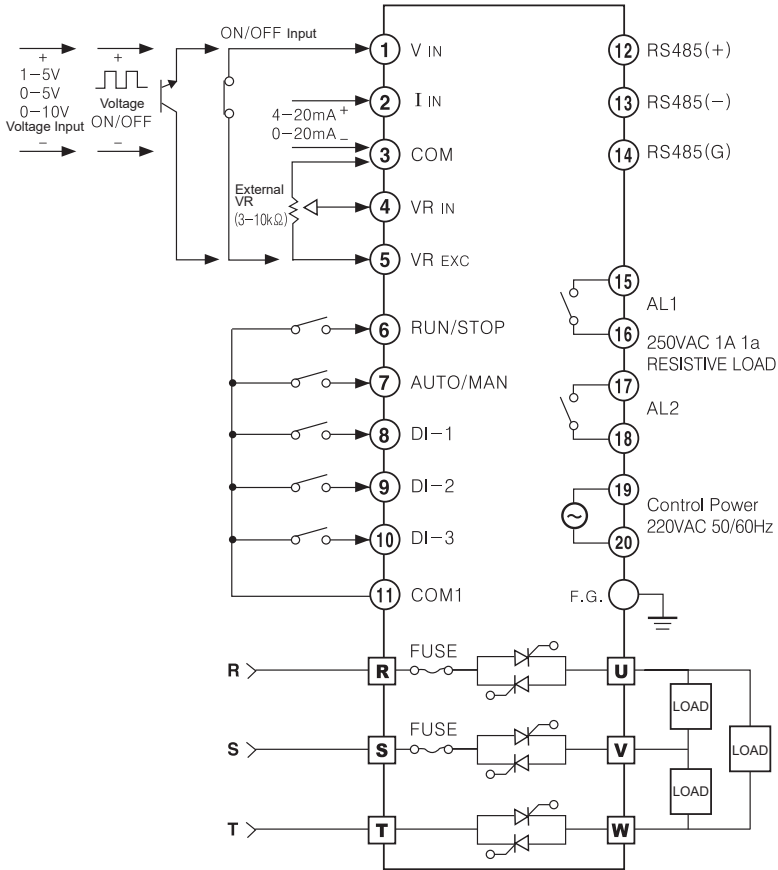

- ※1. Do not mix noise to input cable.
It is recommended to use shield cable, twisted cable as input cable for effective noise.
- ※2. If there is possible to affect inductive noise,
it is recommended to use shielded cable at high-frequency power for effective noise.
- ※3. DI input switch should be for low current and ON resistance should be max. 20Ω
(including cable resistance).
- ※4. DI input terminals are COM, DI-1 to 3, RUN, AUTO.
- ※5. For remote display unit option model,
use connection cable as our standard cable.
- ※6. When connecting ⑥, ⑩, it operates as MANUAL. When connecting, ⑥, ⑦, ⑩, it operates AUTO.

5. Installation and Initial Operation

5.1 Installation

Turn OFF the main power and open the front cover.

Wire it according to the connection diagrams.

5.2 Initial display

When turning ON the power to the unit, front displays flash for 1 sec and it displays product version, rated voltage, rated current and operates RUN mode.

	① Whole flashes	② Displays product version	③ Displays rated voltage	④ Displays rated current	⑤ RUN mode
Single-phase					
3-phase					

5.3 Parameter setting group

5.3.1 Parameters

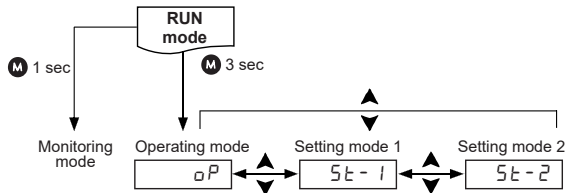

Mode	Descriptions
Monitoring Mode	Monitors input value, load voltage/current/power/resistance, power frequency.
Operating Mode[OP]	Sets parameters for DPU operation
Setting Mode 1[5t-1]	Sets parameters for details set.
Setting Mode 2[5t-2]	Sets parameters for alarm

5.3.2 Monitoring Mode

(1) Single-phase (DPU1 series)

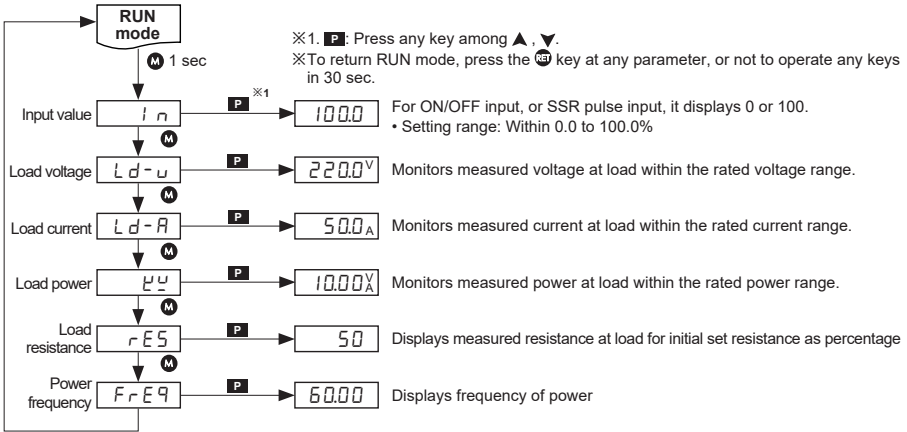

(2) 3-phase (DPU3 series)

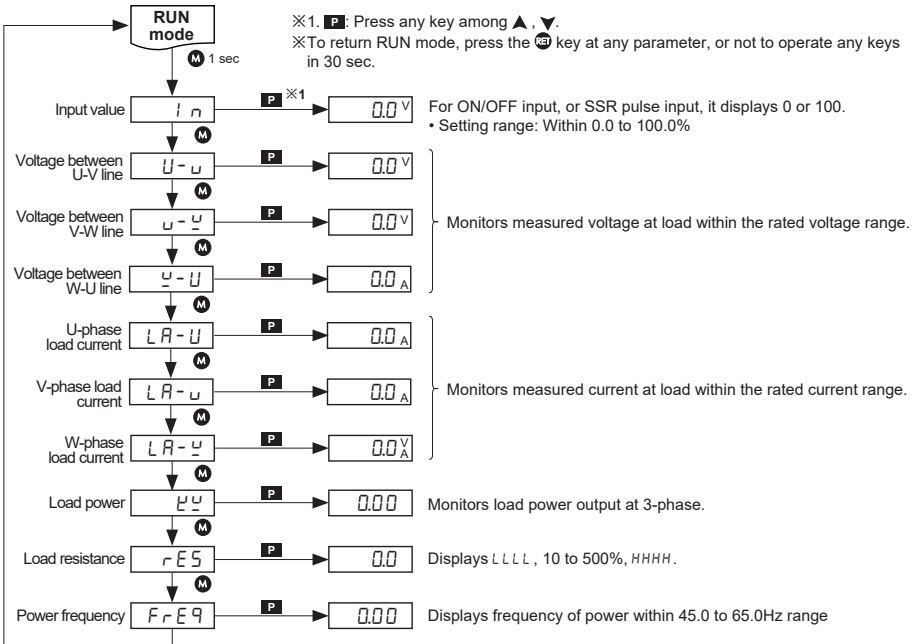

5.3.3 Operation Mode [OP]

※1. **P**: Press any key among \blacktriangle , \blacktriangledown .

※To return RUN mode, press the **⏻** key at any parameter, or not to operate any keys in 30 sec.

※.....: This parameter may or may not appear, depending on the other parameter settings.

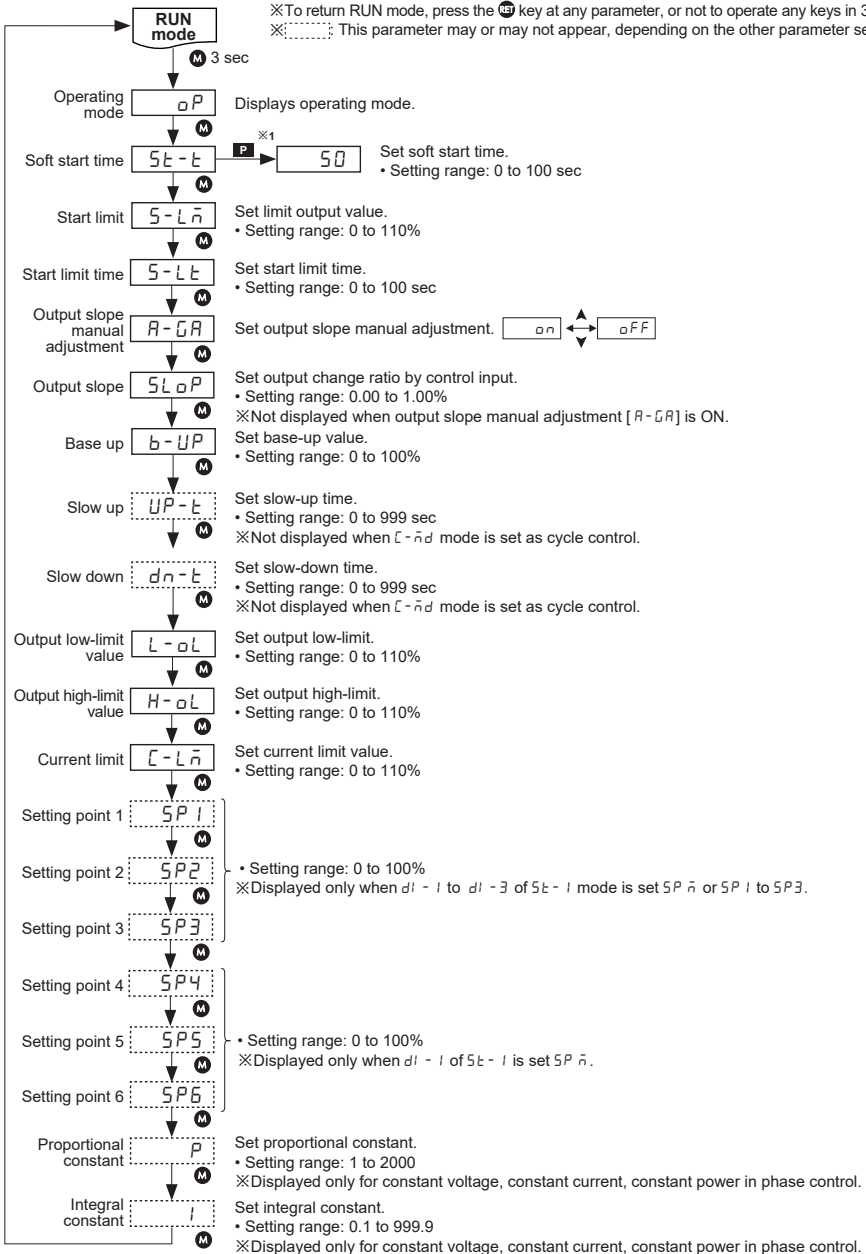

5.3.4 Setting Mode 1 [5t-1]

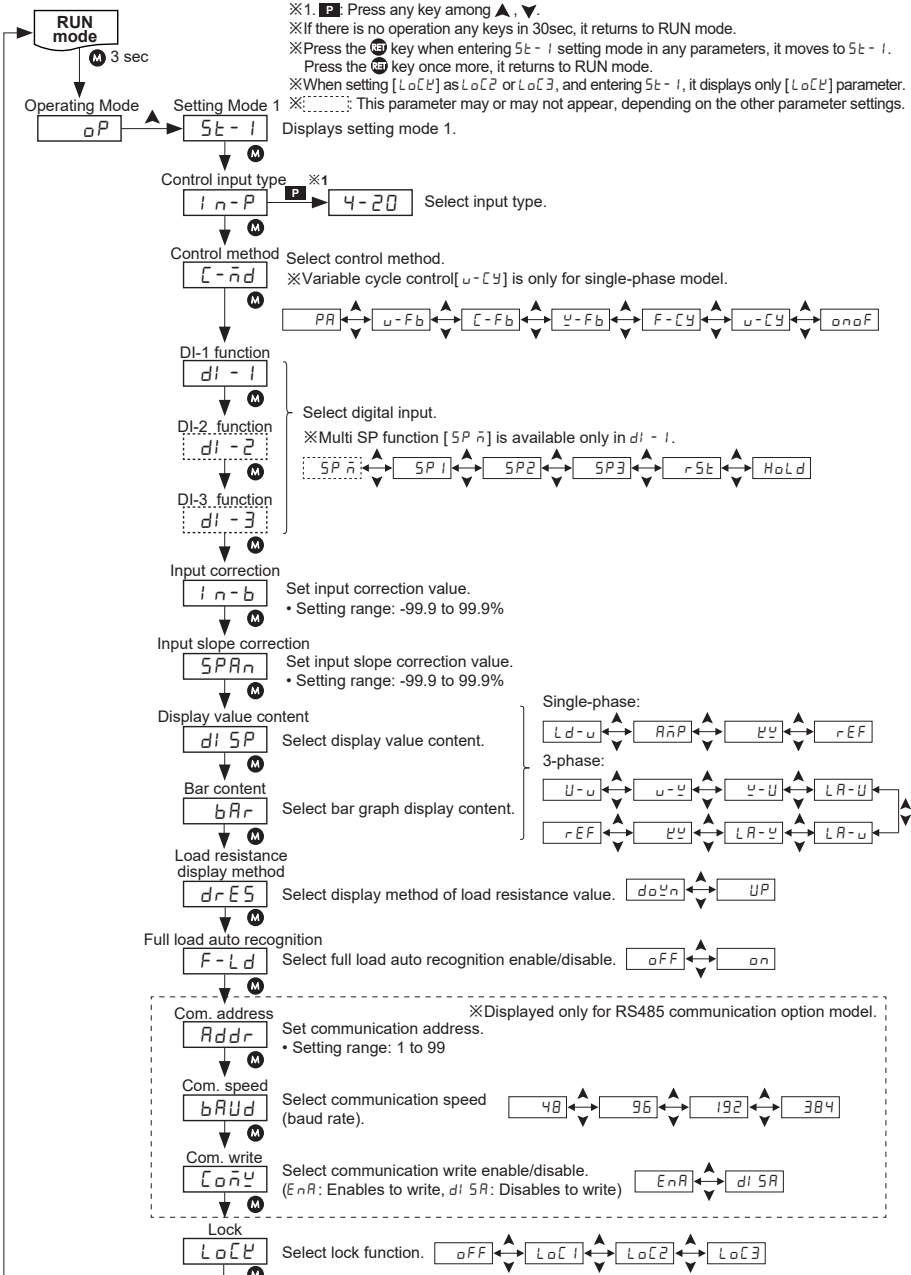

5.3.5 Setting Mode 2 [5t-2]

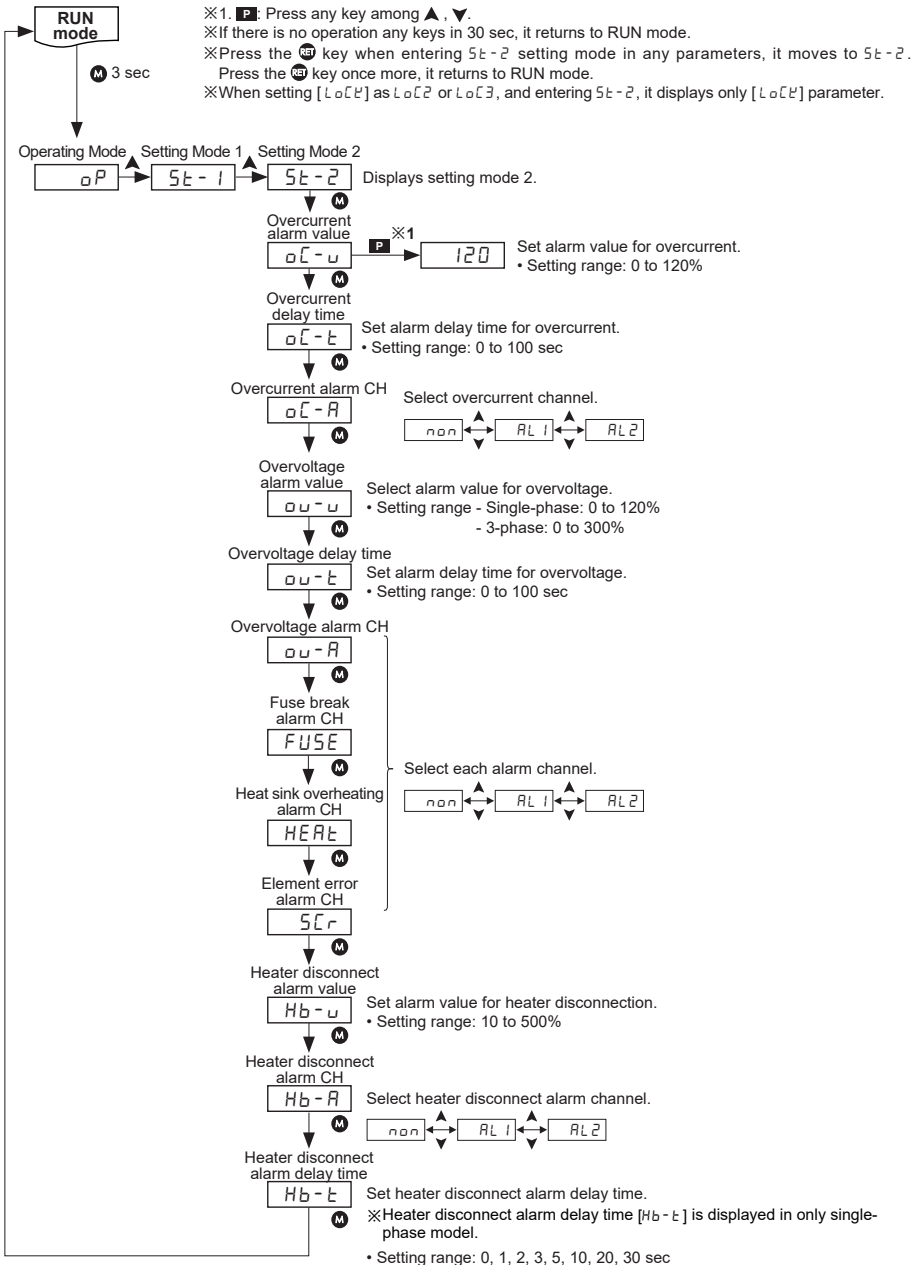

6. Parameter Setting and Functions

6.1 Control input

(1) Input type

Type				Parameter	
AUTO input	Analog input	Current	4-20mA	Input impedance 100Ω	4-20
			0-20mA		0-20
		Voltage	1-5VDC	Input impedance 25Ω	1-5
			0-5VDC		0-5
			0-10VDC		0-10
		ON/OFF input	Voltage pulse	0/12VDC	55r
	No-voltage pulse		ON/OFF	—	
Com. input	RS485	—	—	□□□	
MANUAL input		Internal adjuster	10kΩ	—	—
		External adjuster	3 to 10kΩ	—	—

(2) Input selection

In AUTO input, select it at control input type [i n - P] at setting mode1.

In MANUAL input, set output slope manual adjustment [R - CR] in operating mode as OFF and select the input by the inner 3-level slide switch.

- Output slope manual adjustment [R - CR] setting as OFF: Select the input by the inner 3-level slide switch.

Type	Description
	MAN INT Adjust output slope with the internal adjuster
	MAN EXT Adjust output slope with the external adjuster
	AUTO No function

AUTO/MANUAL selection is available by no.7 and 11 terminals. ON setting is for AUTO input drive and OFF setting is for MANUAL input drive. When AUTO/MANUAL terminal input is OFF, internal AUTO/MANUAL selection switch is available only for setting MAN INT, and MAN EXT.

6.2 Functions

6.2.1 Control method [$\bar{c} - \bar{n}d$]

Control method	Control mode	Parameter
Phase control	Normal mode	PR
	Constant voltage mode	$u - Fb$
	Constant current mode	$\bar{c} - Fb$
	Constant power mode	$\underline{u} - Fb$
Cycle control	Fixed cycle control	$F - \bar{c}Y$
	Variable cycle control	$u - \bar{c}Y$
	ON/OFF control	$onoff$

(1) Normal mode [PR]

It is general output method to divide control angle proportionally according to control input signal and to output it. The below figure is for output characteristics. It may cause lack power and overpower based on the center of control input.

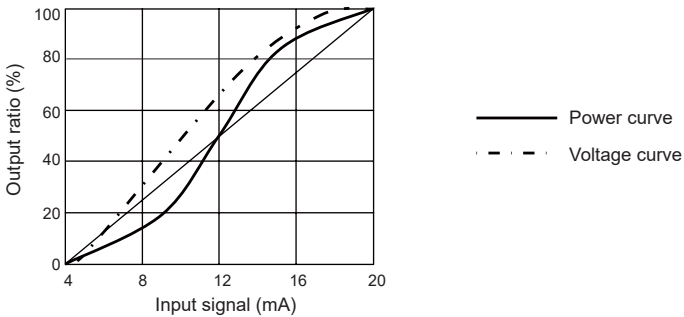

(2) Constant voltage mode [$u - Fb$]

At low temperature coefficient load (iron, chrome, nichrome, etc) of electrical resistance, it outputs constant output which is proportion to control input not to change output voltage for power supply variation, load resistance variation.

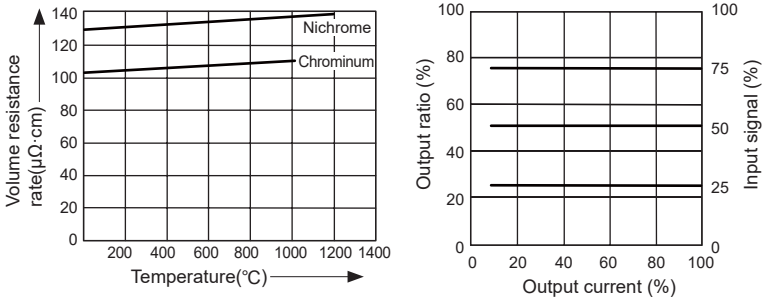

(3) Constant current mode [$C - F_b$]

If temperature coefficient of load (platinum, molybdenum, tungsten, etc) changes 6 to 12 times based on room temperature, it outputs constant current which is proportion to control input not to change output voltage for power supply variation, load resistance variation.

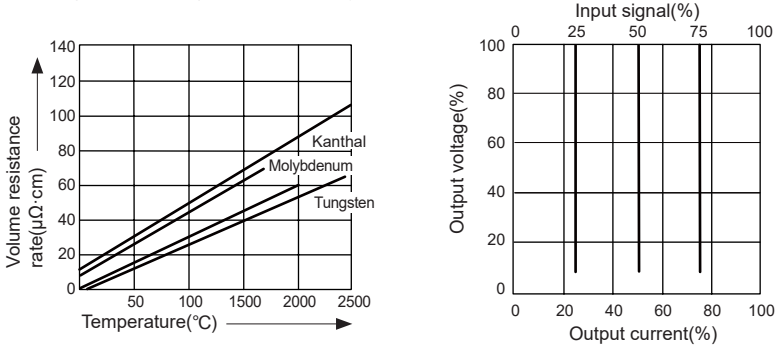
**(4) Constant power mode [$P - F_b$]**

It outputs constant power which is proportion to control input even though load variation and power supply variation. It is proper control method for a heater which resistance value variation by carbide(SiC) heating is big.

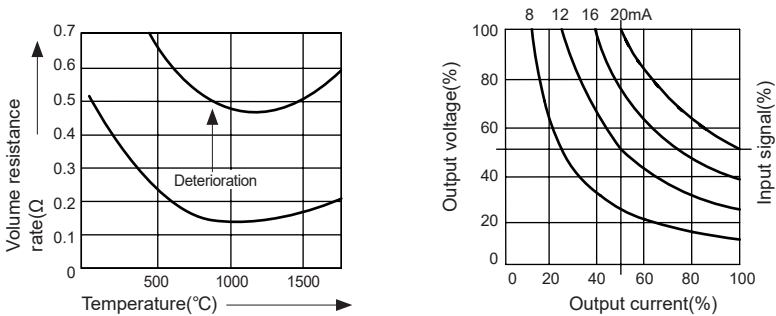

Output characteristics is proper 50% of the curve which connects the point (A) [output voltage 100% × output current 50%] and the point (B) [output voltage 50% × output current 100%].

The current output capacity of this unit should be over two times of load capacity.

(5) Fixed cycle control [F - CY]

During fixed cycle (60 cycles) of load power, it repeats ON/OFF cycle as constant ratio according to control input signal and controls the power supplies on the load.

- Fixed cycle (60 cycles) control – When controlling output as 40%

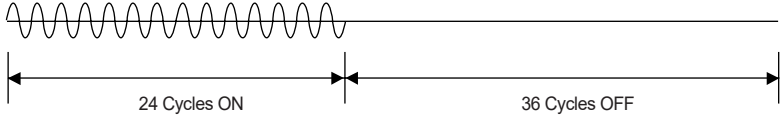

- Fixed cycle (60 cycles) control – When controlling output as 90%

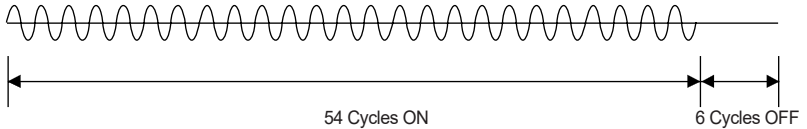

(6) Variable cycle control [V - CY]

Variable cycle control controls required power using min. cycles of AC sine wave according to control input signal and optimize temperature changes of the subject.

- Variable cycle control – When controlling output as 30%

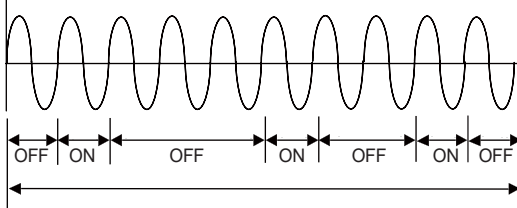

(7) ON/OFF control method [ONOFF]

The method when control input is OFF, output is OFF(0%), when it is ON, output is ON(100%). (same as SSR)

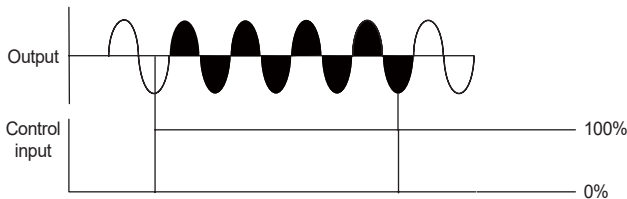

6.2.2 Soft start [5t - t]

When controlling the load which has inrush current (platinum, molybdenum, tungsten, infrared lamp, etc) in power ON, or when control input changes rapidly, it prevents the load to increase output gradually within the set time. Set the time for soft start.

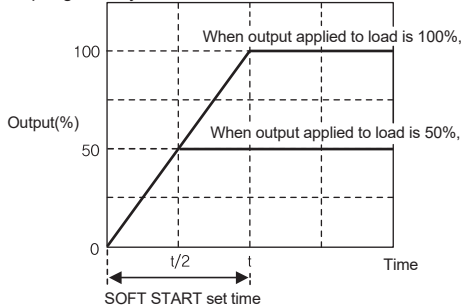

Regardless of control method setting (phase control or cycle control), it operates as phase control.

It operates when it is RUN mode from STOP status after supplying power or reset. (when it reaches to the target output value, soft start function ends.)

When the target output is 0%, (control input 0%), soft start function does not operate.

- Setting range: 0 to 100 (unit: sec)



Ex.

Soft start set time (t) is the time up to 100% increase of output applied to load. When the final target output value is 50%, taken time to reach is t/2.

Reaching time to the final target output value = target output (%) × t

If soft start time is 25 sec, final target output is 80%,

reaching time to the final target output value is $0.8 \times 25 = 20$.

6.2.3 Start limit [5-Ln] and start limit time [5-Lt]

When power is ON, changing to RUN status from STOP status, or alarm reset, set limit output value and time to prevent the inrush current or error current.

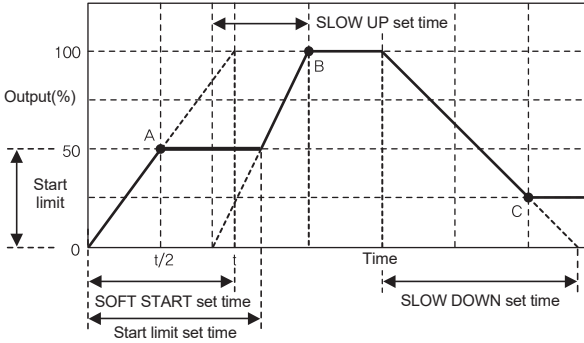

A: Soft start [5-Lt] function ends

B: Slow up [μP-t] function ends

C: Slow down [dn-t] function ends

Regardless of control method setting (phase control or cycle control), it operates as phase control.

- Start limit [5-Ln] setting range: 0 to 110 of output (unit: %)
- Start limit time [5-Lt] setting range: 0 to 100 (unit: sec)

6.2.4 Output slope setting [5-LdP]

This function is to set output changed ratio by control input from 0.00 to 1.00 range.

Output value when setting slope is input(%) X slope value.

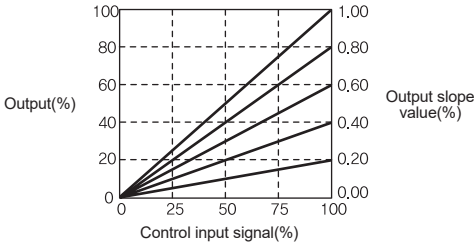

6.2.5 Output slope manual adjustment [R - CR]

This function is to adjust manually (internal or external adjuster) output value ratio for control input. When setting AUTO GAIN function as ON in AUTO operation, [SL OP] is not displayed. It displays slope value by the internal or external adjuster input.

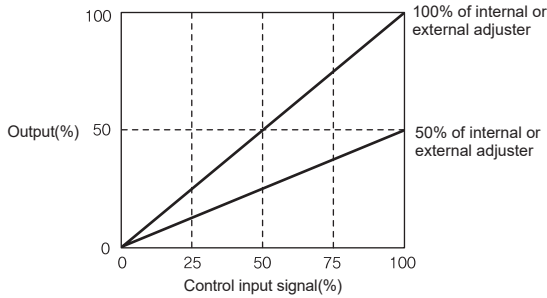

- Output slope manual adjustment [R - CR] setting as ON
: Set output slope by the inner 3-level slide switch

Type	Description
MAN INT <input type="checkbox"/> MAN EXT <input checked="" type="checkbox"/> AUTO <input type="checkbox"/>	MAN INT Adjust output slope with the internal adjuster
	MAN EXT Adjust output slope with the external adjuster
	AUTO No function

6.2.6 Base-up [b - UP]

This function is to add base-up set value to input signal. It is available only when output low-limit value is 0%.

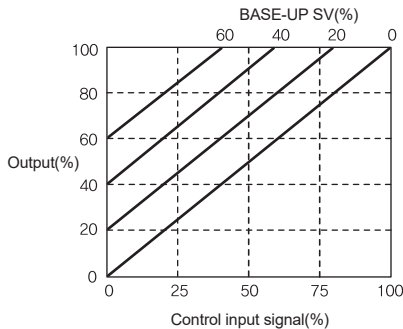

It is limited by start limit value at initial start.

- Setting range: Base-up set value (%) < Output high-limit value
- Output value for Base-up setting: Input(%)×Slope value+Base-up set value

6.2.7 Slow up/Slow down [UP-t / DN-t]

It is same purpose as soft start function.

Soft start starts only one time at first but slow up/slow down function start during operation.

Regardless of control method setting (phase control or cycle control), it operates as phase control.

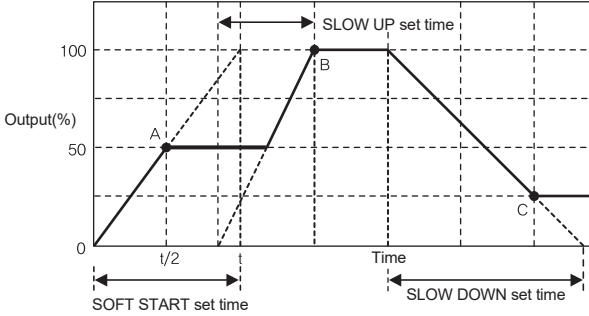

A: Soft start ends

B: Slow up ends

C: Slow down ends

When it reaches to the target output value, slow up/slow down functions end. When it sets as '0', slow up/slow down do not operate.

- Setting range: 0 to 999 (unit: sec)

6.2.8 Output high limit value [H-oL], Output low limit value [L-oL]

This function is to high/low limit output range to protect load.

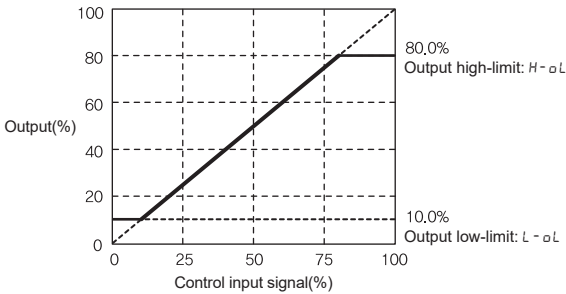

- Setting range: 0 to 110 (unit: %)
(Output low limit value < Output high limit value)

6.2.9 Digital input (DI)

Below functions are available by terminal input.

Digital input has five terminals; AUTO/MANUAL terminal, RUN/STOP terminal, and DI-1 to 3 terminals. Select the function for each input terminal of DI-1 to 3.

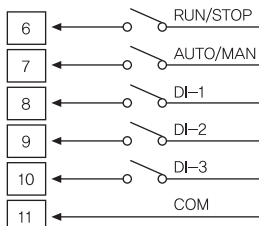

(1) AUTO/MANUAL selection [terminal 7 and 11]

Select AUTO(close)/MANUAL(open) input by terminal input.

AUTO mode controls output according to control input as analog input (voltage, current) or ON/OFF input (including SSR pulse input).

MANUAL mode controls output according to control input as the internal adjuster adjustment or the external adjuster adjustment.

When selecting AUTO (close), the front AUTO indicator turns ON or selecting MANUAL(open), the front AUTO indicator turns OFF.

(2) Run/Stop switching digital input [terminal 6 and 11]

Select RUN(close)/STOP(open) operation status by terminal input.

RUN mode operates as the set contents by control input. STOP mode is standby status.

When selecting RUN(close), the front RUN indicator turns ON or selecting STOP(open), the front RUN indicator turns OFF.

(3) Digital input(DI1 to DI3) settings [terminal 8, 9, 10 and 11(COM)]

Select the each function for each digital input.

When setting ON(close) to DI input, the front EVT indicator turns ON or setting OFF(open), the front EVT indicator turns OFF.

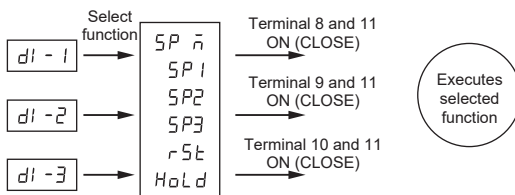

- RESET [r5t]

After selecting RESET function, turn digital input ON(close) and open, this unit resets and re-starts.

- HOLD [HoLd]

After selecting HOLD function and digital input is ON(close), output and display value of this unit is hold. (it operates hold when digital input maintains ON(close) status.)

- Single SP [5P-1, 5P-2, 5P-3]

For single SP, set 5P-1, 5P-2, 5P-3 to each digital input for output to reach the relevant SP. It is available to set individually and duplicated and it is relevant with setting point [5P1 to 5P3].



Ex.

$dI - 1$	$dI - 2$	$dI - 3$	Operating mode SP value set parameter
5P1	5P2	5P3	5P1 (e.g.: 20%)
			5P2 (e.g.: 40%)
			5P3 (e.g.: 60%)

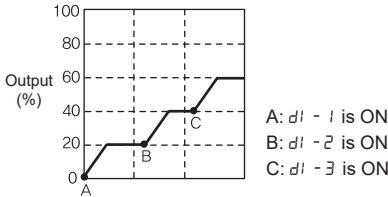

- Multi SP [5P- \bar{n}]

It is available to set total 6 SPs and to control output depending on 3 digital inputs' setting. This function is selectable only in [dI - 1]. When selecting [5P- \bar{n}] at [dI - 1], [dI - 2, dI - 3] parameters are not displayed.

When selecting [5P- \bar{n}] at [dI - 1], 6 parameters to set SPs are displayed in operating mode. (5P1, 5P2, 5P3, 5P4, 5P5, 5P6)



Ex.

	$dI - 1$	$dI - 2$	$dI - 3$	Operating mode SP value set parameter
A	○	X	X	5P1 (e.g.: 20%)
B	X	○	X	5P2 (e.g.: 40%)
C	○	○	X	5P3 (e.g.: 60%)
D	X	X	○	5P4 (e.g.: 80%)
E	○	X	○	5P5 (e.g.: 100%)
F	X	○	○	5P6 (e.g.: 0%)
G	○	○	○	—

○: Close, X: Open

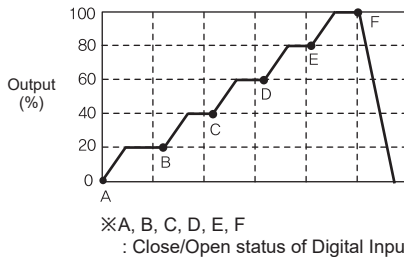

6.2.10 Proportional and integral constant set of feedback control

Proportional integral control: This is the combination of proportional control and integral control.

Proportional control operates soft control without overshoot and hunting for the set value.

Integral control modifies offset automatically to reach the set value stably.

The optimal values of proportional constant and integral constant are set as factory defaults.

When changing proportional constant and integral constant, it may cause response delay in feedback control or overshoot or hunting.

Proportional constant set [P], integral constant set [I] parameters are displayed when control mode is constant voltage, constant current, constant power mode in phase control.

(1) Proportional constant set [P]

It compensates error from the target value proportionally.

If proportional constant value is small, response is fast and it may cause overshoot or hunting. If proportional constant value is big, response is slow.

- Setting range: 0(0%) to 2000(100%)

(2) Integral constant set [I]

It compensates cumulative error from the target value.

The set integral constant is the time when proportional value and integral value are equal.

If integral constant value is small, response is fast and it may cause overshoot or hunting.

If integral constant value is big, response is slow.

- Setting range: 0.1 to 999.9 (unit: sec)

6.2.11 Input correction [i n - b]

It compensates the offset between actual input value and measured input value.

- Setting range: -99.9 to 99.9 (unit: %)

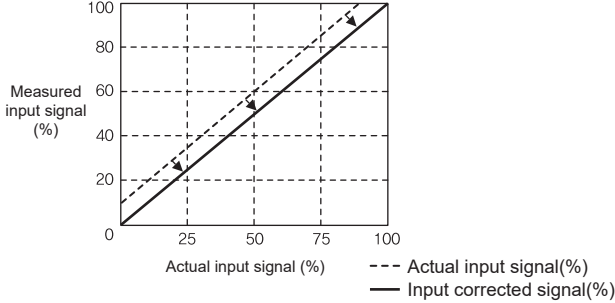

Ex.

Input type is 4 to 20mA,

When 4mA is applied and the input monitor value displays 0.5%, set *i n - b* as -0.5 and the input monitor value displays as 0.0%.

6.2.12 Input slope correction [5 P R n]

It compensates the slope of the measured 100% input for actual 100% input value.

- Setting range: -99.9 to 99.9 (unit: %)

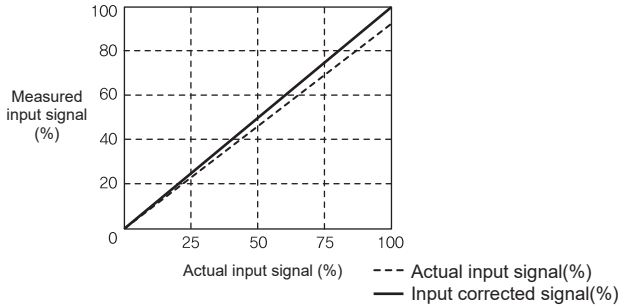

Ex.

Input type is 4 to 20mA.

When 20mA is applied and the input monitor value displays 99.5%, set *5 P R n* as 0.5 and the input monitor value is 100.0%.

6.2.13 Display value content [d i S P], bar graph content [b R r]

You can select display value content for the display part and bar graph in RUN mode.

- Display range
 - Single-phase: [L d - u], [R n P], [U U], [r E F]
 - 3-phase: [U - u], [u - U], [U - U], [L R - U], [L R - u], [L R - U], [U U], [r E F]

6.2.14 Load resistance display method [$d_r E 5$]

This function is for display load resistance [$r E 5$] into a percentage in monitoring mode when disconnecting the parallel load. You can select this value as increase rate of load resistance [$U P$] or as decrease rate of number of loads [$d o \downarrow n$].



Note

Decrease rate of number of loads [$d o \downarrow n$] displays correct decrease rate only when the connected each load resistance is same.



Ex.

R_1 to $R_{10} = 10\Omega$ of each and load resistance (R) = 1Ω
When disconnecting R_1 to R_5 ,

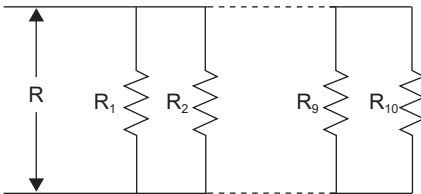

① Increase rate of load resistance [$U P$]

It is based on 100% of load resistance(R), 1Ω . When disconnected R_1 to R_5 , load resistance is 2Ω and load resistance [$r E 5$] in monitoring mode displays 200%.

② Decrease rate of number of loads [$d o \downarrow n$]

It is based on 100% of 10 loads (R_1 to R_{10}). When disconnected R_1 to R_5 , the number of load are 5(R_6 to R_{10}) and load resistance [$r E 5$] in monitoring mode displays 50%.

6.2.15 Full load auto recognition [F-Ld]

When operating load recognition function, it outputs 100% for 3 sec. Do not use this unit to the device which has problem 100% output of load.

Set F-Ld as on in Setting Mode 1 [5t-1] group and press the **M** key, load auto recognition function operates. According to secular changes of the load, execute this function regularly.



Note

Be sure that when auto recognition starts, it operates 100% output for 3 sec.



Caution

Do not execute this function as on without profession's consultations. When executing this function, voltage, current outputs fully. Be sure that it may cause damage to the load.

When using special load using low voltage and high current such as (super)tantalum, SiC, molybdenum, tungsten, etc, it may cause heater disconnect alarm [H-bt].

This alarm does not have problem in operation but it occurs when it does not detect the load when using as low voltage. Set the below notes to clear the alarm.



Note

When using special load such as (super) tantalum, SiC, molybdenum, tungsten, [H-bt] alarm clear method:

- Set load resistance display method [dRE5] as UP in Setting Mode 1 [5t-1].
- Set heater disconnect alarm value [Hb-u] as 500 in Setting Mode 2 [5t-2].

6.2.16 Parameter lock [LoL]

This function is to limit parameter set value check and change.

	oFF	LoL1	LoL2	LoL3
Operating Mode set group	●	●	●	◐
Setting Mode 2 set group	●	●	◐	◐
Setting Mode 1 set group	●	◐	X	X

●: Enable to check and set, ◐: Enable to check/Disable to set, X: Disable to check

6.3 Alarm

Alarm	Display	Operation in alarm	Alarm clear
Overcurrent alarm	$\sigma - \zeta$	Stops output (SCR OFF)	<ul style="list-style-type: none"> • Re-supply the power. • RESET (RESET key) • Switch to STOP mode
Overvoltage alarm	$\sigma - \upsilon$		
Fuse break alarm	$FUSE^{\times 1}$	$\times 2$	
Heatsink overheat alarm	$t E \bar{n} P$	Stops output (SCR OFF)	
Element error alarm	$\zeta \zeta r^{\times 1}$		
Heater break alarm	$H - b \bar{t}$	Continues operation	Automatically cleared within the setting range

$\times 1$: When it cannot return by re-supplying power because fuse is disconnected or element is error, refer to '8. Maintenance'.

$\times 2$: For single-phase model, output stops.

For 3-phase model, when 1-phase break, it maintains output and when 2-phase break, it stops output.

6.3.1 Overcurrent alarm [$\sigma - \zeta - A$]

When overcurrent alarm occurs, output stops and alarm maintains. [$\sigma - \zeta$] flashes for 0.5 sec in the display part and the EVT indicator flashes for 0.5 sec.

When setting as [$n \sigma n$], alarm output does not occur but [$\sigma - \zeta$] flashes.

Alarm clears when re-supplying power, reset, or stop the unit.

(1) Overcurrent alarm value setting [$\sigma - \zeta - U$]

Set overcurrent alarm value within 0.0 to 120.0% of rated current range.

(2) Overcurrent alarm delay time [$\sigma - \zeta - t$]

Set overcurrent alarm delay time within 0 to 100 sec range. After the set time, over current alarm occurs.

6.3.2 Current limit [$\zeta - L \bar{n}$]

This function limits current when using big inrush load to protect thyristor.

Especially for voltage feedback, current for load resistance value flows and it may over the rated thyristor only voltage control. Therefore, it limits current to prevent over the rated current.

- Setting range: 0 to 110% (unit: %)

6.3.3 Overvoltage alarm [OV - A]

When overvoltage alarm occurs, output stops and alarm maintains.

[OV - A] flashes for 0.5 sec in the display part and the EVT indicator flashes for 0.5 sec.

Alarm clears when re-supplying power, reset, or stop the unit.

(1) Overvoltage alarm value setting [OV - U]

Set overvoltage alarm value within the range from 0 to 120% of the rated voltage for single-phase model, and from 0 to 300% of the rated voltage for 3-phase model.

(2) Overvoltage alarm delay time [OV - t]

Set overvoltage alarm delay time within 0 to 100 sec range. After the set time, overvoltage alarm occurs.

6.3.4 Fuse disconnection alarm [FUSE]

For single-phase model, when fuse disconnection alarm occurs, output stops.

For 3-phase model, when single-phase break, it maintains output and when 2-phase break, it stops output.

[FUSE] flashes for 0.5 sec in the display part and the EVT indicator flashes for 0.5 sec.

Alarm clears when re-supplying power, reset, or stop the unit.

6.3.5 Heatsink overheating alarm [HEAT]

When the temperature of a heat sink is over 75°C, heat sink overheating alarm occurs. [HEAT] flashes for 0.5 sec in the display part and AL1 or AL2 indicator turn ON. When heatsink overheating alarm occurs, output stops and alarm maintains. Alarm clears when re-supplying power, reset, or stop the unit after cooling a heatsink.

6.3.6 Element error alarm [ELR]

Even though output is 0% and 10% of rated current or over current flows for over 3 sec (or over 5 cycle) continuously, element error alarm occurs.

When element error alarm occurs, output stops and alarm maintains. [ELR] flashes for 0.5 sec in the display part and the EVT indicator flashes for 0.5 sec.

Alarm clears when re-supplying power, reset, or stop the unit.

6.3.7 Heater disconnection alarm [$H_b - R$]

When load resistance display method is set as [UP], it is over the set value, this alarm occurs. [$H - bE$] and display value flashes for 2 sec in turn in the display part and EVT indicator flashes for 0.5 sec.

Even though heater disconnect alarm occurs, control operation continues.

It is cleared automatically when the value is below the SV of heater disconnect alarm value.

(1) Heater disconnection alarm value setting [$H_b - u$]

Regardless of control method (phase control, cycle control), it operates. For the operation, over 10% of control output (phase control, cycle control) and over 30% of rated current are required.

- Setting range: 10 to 500 (unit: %)

Hysteresis of heater disconnect alarm is fixed as 1% for ON/OFF interval.



Ex.

When SV for heater disconnect alarm is 50%, alarm turns ON at 50%, alarm turns OFF at 49%.

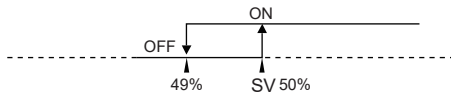

(2) Heater disconnection alarm delay time [$H_b - t$]

When load resistance display method is set as [$doun$] and load resistance value is under the SV of [$H_b - u$], alarm disconnection alarm occurs after the set delay time.

This can be set only in single-phase model.

- Setting range: 0, 1, 2, 3, 5, 10, 20, 30 (unit: sec)

7. Factory Default

(1) Operation mode

Parameter	Default	Parameter	Default
S _t -t	0000	C-L _n	1100
S-L _n	1100	SP1	0000
S-L _t	0000	SP2	0000
R-GA	oFF	SP3	0000
SLoP	1000	SP4	0000
b-UP	0000	SP5	0000
UP-t	0003	SP6	0000
dn-t	0003	P	0150
L-oL	0000	I	0200
H-oL	1100		

(2) Setting mode 1

Parameter	Default	Parameter	Default
I _n -P	4-20	bAr	Single-phase L _d -u
C-n _d	PA		3-phase U-u
dI-1	SP _n	drE5	do ₂ n
dI-2	SP1	F-L _d	oFF
dI-3	SP1	Rddr	0001
I _n -b	0000	bAUd	384
SPAn	0000	Co _n U	EnA
dI5P	Single-phase L _d -u	LoC _U	oFF
	3-phase U-u		

(3) Setting mode 2

Parameter	Default	Parameter	Default
oC-u	1100	FUSE	AL1
oC-t	0005	HEAt	AL1
oC-R	AL1	SCr	AL1
ou-u	1100	Hb-u	0100
ou-t	0005	Hb-R	AL2
ou-R	AL1	Hb-t	Single-phase 30

8. Maintenance

8.1 Fuse

To prevent accident, replace a fuse every two years.

Turn OFF the power and remove the power to remove the fuse which is in the product.

8.1.1 Single-phase (DPU1 series)

Fuse position by each model

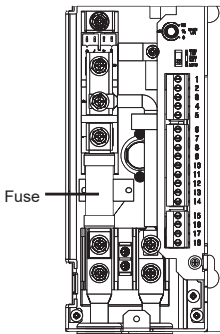

A type

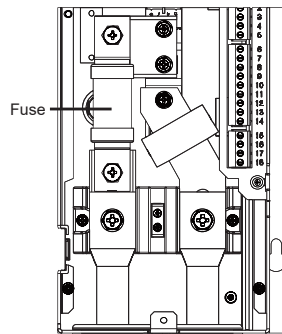

B type

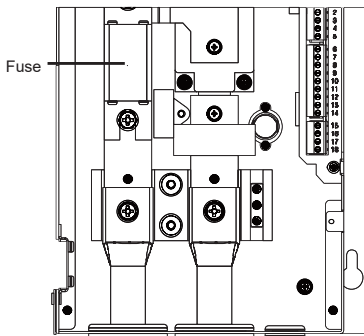

C type

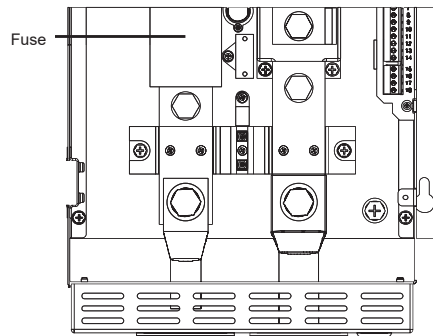

D type



Warning

- Use the designated Fuse.
- After changing the fuse, you must check the fuse is installed correctly.

8.1.2 3-phase (DPU3 series)

Fuse position by each model

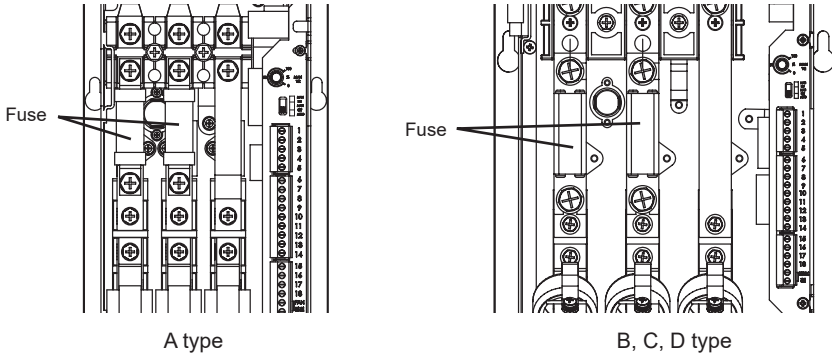

Warning

- Use the designated Fuse.
- After changing the fuse, you must check the fuse is installed correctly.

8.2 Thyristor (SCR)

There is one output SCR element in single-phase model (DPU1 Series), and three output SCR elements in 3-phase model (DPU3 Series).

It is normal status when the resistance between K and G is 10 to 100Ω during checking SCR elements.

Refer to the below circuit diagram for accurate maintenance.

Assemble this unit as below circuit diagram. (Load indicator turns OFF)

When shorting TEST 1 at gate momentarily, open it to turn ON the load indicator.

When the load indicator does not turn ON, SCR elements are bad conditions.

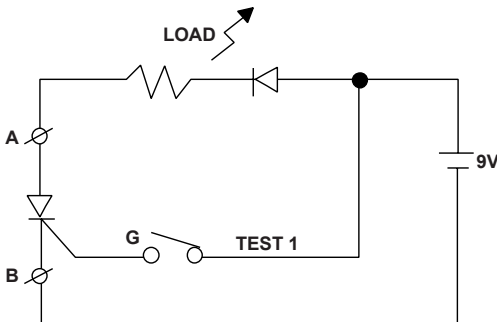

9. Modbus Mapping Table

9.1 Function code 3 (0×03) = Read holding resistors

(1) Request

Master to Slave							
0×01	0×03	0×00	0×00	0×00	0×16	xx	xx
Add.	Com- mand	Start address		Number of data		CRC 16	
		High	Low	High	Low	High	Low

(2) Response

Slave to Master									
0×01	0×03	0×10	0×03	0×E8	...	0×03	0×E8	xx	xx
Add.	Response command	Number of data	1st data		...	16th data		CRC 16	
			High	Low	...	High	Low	High	Low

(3) Error

Slave to Master				
0×01	0×83	xx	xx	xx
Address	Response command	Exception code	CRC 16	

※Exception code

0×01: Not supported command code.

0×02: Starting address of required data and transmittable address are different.

0×03: The number of required data is over than the number of transmittable data.

0×04: Transmittable data does not process properly.

9.2 Function code 4 (0×04) = Read input resistors

(1) Request

Master to Slave							
0×01	0×04	0×00	0×00	0×00	0×10	xx	xx
Address	Command	Start address		Number of data		CRC 16	
		High	Low	High	Low	High	Low

(2) Response

Slave to Master									
0×01	0×04	0×10	0×03	0×E8	...	0×03	0×E8	xx	xx
Address	Response command	Number of data	1st data		...	16th data		CRC 16	
			High	Low	...	High	Low	High	Low

(3) Error

Slave to Master				
0×01	0×84	xx	xx	xx
Address	Response command	Exception code	CRC 16	

※Exception code

0×01: Not supported command code.

0×02: Starting address of required data and transmittable address are different.

0×03: The number of required data is over than the number of transmittable data.

0×04: Transmittable data does not process properly.

9.3 Function code 6 (0×06) = Write single registers

(1) Request

Master to Slave							
0×01	0×06	0×00	0×00	0×03	0×E8	xx	xx
Address	Command	Station		Data		CRC 16	
		High	Low	High	Low	High	Low

(2) Response

Slave to Master							
0×01	0×06	0×00	0×00	0×03	0×E8	xx	xx
Address	Command	Station		Data		CRC 16	
		High	Low	High	Low	High	Low

(3) Error

Slave to Master							
0×01	0×86	xx	xx	xx			
Address	Response command	Exception code	CRC 16				

※Exception code

0×01: Not supported command code.

0×02: Starting address of required data and transmittable address are different.

0×03: The number of required data is over than the number of transmittable data.

0×04: Transmittable data does not process properly.

9.4 Function code 16 (0×10) = Write multiple registers

(1) Request

Master to Slave								
0×01	0×10	0×00	0×00	0×00	0×10	0×20	xx	xx
Address	Command	Start address		Number of data		Number of byte	CRC 16	
		High	Low	High	Low		High	Low

(2) Response

Slave to Master							
0×01	0×10	0×00	0×00	0×03	0×E8	xx	xx
Address	Command	Station		Data		CRC 16	
		High	Low	High	Low	High	Low

(3) Error

Slave to Master							
0×01	0×90	xx	xx	xx			
Address	Response Command	Exception code	CRC 16				

※Exception code

0×01: Not supported command code.

0×02: Starting address of required data and transmittable address are different.

0×03: The number of required data is over than the number of transmittable data.

0×04: Transmittable data does not process properly.

9.5 Address mapping table

9.5.1 Input registers

(1) Single-phase (DPU1 series)

No.(address)	Item	Factor
300001(0000)	Output voltage	*0.1
300002(0001)	Load current	*0.1
300003(0002)	Power	*0.1
300004(0003)	Load resistance	*0.1
300005(0004)	Power frequency	*0.01
300101(0064)	Product number H	00
300102(0065)	Product number L	00
300103(0066)	Hardware version	10
300104(0067)	Software version	10
300105(0068)	Model name 1	"DP"
300106(0069)	Model name 2	"2-"
300107(006A)	Model name 3	"00"
300108(006B)	Model name 4	" "
300109(006C)	Model name 5	" "
300110(006D)	Model name 6	" "
300111(006E)	Model name 7	" "
300112(006F)	Model name 8	" "
300113(0070)	Model name 9	" "
300114(0071)	Model name 10	" "
300115(0072)	Reserved	Reserved
300116(0073)	Reserved	Reserved
300117(0074)	Reserved	Reserved
300118(0075)	Coil start address	0
300119(0076)	Coil quantity	0
300120(0077)	Input start address	0
300121(0078)	Input quantity	0
300122(0079)	Holding reg start address	0
300123(007A)	Holding reg quantity	32
300124(007B)	Input reg start address	0
300125(007C)	Input reg quantity	5

(2) 3-phase (DPU3 series)

Address	Item	Factor
300001(0000)	Load voltage between U-V line (Vrms)	*0.1
300002(0001)	Load voltage between V-W line (Vrms)	*0.1
300003(0002)	Load voltage between W-U line (Vrms)	*0.1
300004(0003)	Load current of U-phase (Arms)	*0.1
300005(0004)	Load current of V-phase (Arms)	*0.1
300006(0005)	Load current of W-phase (Arms)	*0.1
300007(0006)	Power	*0.01
300008(0007)	Load resistance (% display for initial load)	*0.1
300009(0008)	Power frequency	*0.01
300101(0064)	Product number H	00
300102(0065)	Product number L	00
300103(0066)	Hardware version	10
300104(0067)	Software version	10
300105(0068)	Model name 1	"DP"
300106(0069)	Model name 2	"2."
300107(006A)	Model name 3	"00"
300108(006B)	Model name 4	" "
300109(006C)	Model name 5	" "
300110(006D)	Model name 6	" "
300111(006E)	Model name 7	" "
300112(006F)	Model name 8	" "
300113(0070)	Model name 9	" "
300114(0071)	Model name	" "
300115(0072)	Reserved	Reserved
300116(0073)	Reserved	Reserved
300117(0074)	Reserved	Reserved
300118(0075)	Coil start address	0
300119(0076)	Coil quantity	0
300120(0077)	Input start address	0
300121(0078)	Input quantity	0
300122(0079)	Holding reg start address	0
300123(007A)	Holding reg quantity	32
300124(007B)	Input reg start address	0
300125(007C)	Input reg quantity	5

9.5.2 Holding registers

(1) Single-phase (DPU1 series)

No. (Address)	Item		Factor
400001 (0000)	Reference Value	—	*0.1 (0 to 1000)
400002 (0001)	Start Limit Time	$S-Lt$	0 to 100
400003 (0002)	Start Limit	$S-L\bar{n}$	*0.1 (0 to 1100)
400004 (0003)	Soft Start Time	$S\bar{t}-t$	0 to 100
400005 (0004)	Output High-Limit	$H-oL$	*0.1 (0 to 1100)
400006 (0005)	Output Low-Limit	$L-oL$	*0.1 (0 to 1100)
400007 (0006)	Remote SP1	$SP1$	*0.1 (0 to 1000)
400008 (0007)	Remote SP2	$SP2$	*0.1 (0 to 1000)
400009 (0008)	Remote SP3	$SP3$	*0.1 (0 to 1000)
400010 (0009)	Remote SP4	$SP4$	*0.1 (0 to 1000)
400011 (000A)	Remote SP5	$SP5$	*0.1 (0 to 1000)
400012 (000B)	Remote SP6	$SP6$	*0.1 (0 to 1000)
400013 (000C)	Slow Up Time	$U\bar{P}-t$	0 to 999
400014 (000D)	Slow Down Time	$d\bar{n}-t$	0 to 999
400015 (000E)	Current Limit	$\bar{C}-L\bar{n}$	*0.1 (0 to 1100)
400016 (000F)	Over current value	$o\bar{C}-u$	*0.1 (0 to 1200)
400017 (0010)	Over current time	$o\bar{C}-t$	0 to 100
400018 (0011)	Over voltage value	$o\bar{v}-u$	*0.1 (0 to 1200)
400019 (0012)	Over voltage time	$o\bar{v}-t$	0 to 100
400020 (0013)	Load detector alarm value	$Hb-u$	*0.1 (100 to 5000)
400021 (0014)	Display selected contents	$di SP$	0 to 3 0: $Ld-u$, 1: $R\bar{n}P$, 2: $U\bar{U}$, 3: rEF
400022 (0015)	Bar graph's content	$b\bar{R}r$	0 to 3 0: $Ld-u$, 1: $R\bar{n}P$, 2: $U\bar{U}$, 3: rEF
400023 (0016)	Control integer KP value	P	1 to 2000
400024 (0017)	Control integer KI value	i	*0.1 (1 to 9999)
400025 (0018)	Control Method	$\bar{C}-\bar{n}d$	0 to 6 0: $F-CY$, 1: $u-CY$, 2: $o\bar{n}oF$, 3: PR , 4: $u-Fb$, 5: $\bar{C}-Fb$, 6: $U-Fb$
400026 (0019)	Digital input 1	$di - 1$	0 to 5
400027 (001A)	Digital input 2	$di - 2$	0: $SP\bar{n}$, 1: $SP1$, 2: $SP2$, 3: $SP3$,
400028 (001B)	Digital input 3	$di - 3$	4: rSt , 5: $H\bar{o}Ld$

No. (Address)	Item		Factor
400029 (001C)	Auto ref input selector	<i>I n - P</i>	0 to 6 0: 4-20, 1: 0-20, 2: 1-5, 3: 0-5, 4: 0-10, 5: 55r, 6: 00n
400030 (001D)	Load resistance display method	<i>drES</i>	0 to 1 0: 000n, 1: UP
400031 (001E)	Operation	—	Bit0... Fault Bit1... I-OC Bit2... Over current Bit3... Over volt Bit4... Over temp Bit5... Fuse cut Bit6... Phase loss Bit7... Load open Bit8... SCR error Bit9... Freq error Bit10... Run/Stop Bit11... Auto/Manual Bit12... EMS Power
400032 (001F)	Output slope	<i>SL oP</i>	*0.001 (0 to 1000)
400033 (0020)	Base Up	<i>b-UP</i>	*0.1 (0 to 1000)
400034 (0021)	Input correction	<i>I n - b</i>	*0.1 (-999 to 999)
400035 (0022)	Input slope correction	<i>SPRn</i>	*0.1 (-999 to 999)
400036 (0023)	Overcurrent alarm output	<i>oC-R</i>	0 to 2 0: non, 1: RL 1, 2: RL 2
400038 (0025)	Overvoltage alarm output	<i>ou-R</i>	
400039 (0026)	Fuse alarm	<i>FUSE</i>	
400041 (0028)	Alarm heat sink temperature alarm	<i>HEALt</i>	
400042 (0029)	SCR error alarm	<i>SCR</i>	
400043 (002A)	Heater break alarm	<i>Hb-R</i>	
400044 (002B)	Auto Gain	<i>A-GA</i>	0 to 1 0: oFF, 1: on
400045 (002C)	Heater Break Time	<i>Hb-t</i>	0 to 7 0: 0, 1: 1, 2: 2, 3: 3, 4: 5, 5: 10, 6: 20, 7: 30

(2) 3-phase (DPU3 series)

No. (Address)	Item		Factor
400001 (0000)	Reference Value	—	*0.1 (0 to 1000)
400002 (0001)	Start Limit Time	$S-Lt$	0 to 100
400003 (0002)	Start Limit	$S-L\bar{n}$	*0.1 (0 to 1100)
400004 (0003)	Soft Start Time	$S\bar{t}-t$	0 to 100
400005 (0004)	Output High-Limit	$H-oL$	*0.1 (0 to 1100)
400006 (0005)	Output Low-Limit	$L-oL$	*0.1 (0 to 1100)
400007 (0006)	Remote SP1	$SP1$	*0.1 (0 to 1000)
400008 (0007)	Remote SP2	$SP2$	*0.1 (0 to 1000)
400009 (0008)	Remote SP3	$SP3$	*0.1 (0 to 1000)
400010 (0009)	Remote SP4	$SP4$	*0.1 (0 to 1000)
400011 (000A)	Remote SP5	$SP5$	*0.1 (0 to 1000)
400012 (000B)	Remote SP6	$SP6$	*0.1 (0 to 1000)
400013 (000C)	Slow Up Time	$UP-t$	0 to 999
400014 (000D)	Slow Down Time	$d\bar{n}-t$	0 to 999
400015 (000E)	Current Limit	$\bar{C}-L\bar{n}$	*0.1 (0 to 1100)
400016 (000F)	Over current value	$o\bar{C}-v$	*0.1 (0 to 1200)
400017 (0010)	Over current time	$o\bar{C}-t$	0 to 100
400018 (0011)	Over voltage value	$o\bar{v}-v$	*0.1 (0 to 3000)
400019 (0012)	Over voltage time	$o\bar{v}-t$	0 to 100
400020 (0013)	Load detector alarm value	$Hb-v$	*0.1 (100 to 5000)
400021 (0014)	Display selected contents	$di\ SP$	0 to 3 0: $U-v$, 1: $v-v$, 2: $v-U$, 3: $L\bar{R}-U$, 4: $L\bar{R}-v$, 5: $L\bar{R}-v$, 6: $v-v$, 7: rEF
400022 (0015)	Bar graph's content	$b\bar{R}r$	0 to 3 0: $U-v$, 1: $v-v$, 2: $v-U$, 3: $L\bar{R}-U$, 4: $L\bar{R}-v$, 5: $L\bar{R}-v$, 6: $v-v$, 7: rEF
400023 (0016)	Control integer KP value	P	1 to 2000
400024 (0017)	Control integer KI value	I	*0.1 (1 to 9999)
400025 (0018)	Control Method	$\bar{C}-\bar{n}d$	1 to 6 1: $F-CY$, 2: $o\bar{n}oF$, 3: PR , 4: $v-Fb$, 5: $\bar{C}-Fb$, 6: $v-Fb$
400026 (0019)	Digital input 1	$di - 1$	0 to 5
400027 (001A)	Digital input 2	$di - 2$	0: $SP\bar{n}$, 1: $SP1$, 2: $SP2$, 3: $SP3$,
400028 (001B)	Digital input 3	$di - 3$	4: $r5t$, 5: $H\bar{o}Ld$

No. (Address)	Item		Factor
400029 (001C)	Auto ref input selector	<i>i n - P</i>	0 to 6 0: 4-20, 1: 0-20, 2: 1-5, 3: 0-5, 4: 0-10, 5: 55r, 6: 00n
400030 (001D)	Load resistance display method	<i>d r E S</i>	0 to 1 0: d0zn, 1: UP
400031 (001E)	Operation	—	Bit0... Fault Bit1... I-OC Bit2... Over current Bit3... Over volt Bit4... Over temp Bit5... Fuse cut Bit6... Phase loss Bit7... Load open Bit8... SCR error Bit9... Freq error Bit10... Run/Stop Bit11... Auto/Manual Bit12... EMS Power
400032 (001F)	Output slope	<i>S L o P</i>	*0.001 (0 to 1000)
400033 (0020)	Base Up	<i>b - U P</i>	*0.1 (0 to 1000)
400034 (0021)	Input correction	<i>i n - b</i>	*0.1 (-999 to 999)
400035 (0022)	Input slope correction	<i>S P R n</i>	*0.1 (-999 to 999)
400036 (0023)	Overcurrent alarm output	<i>o C - R</i>	0 to 2 0: n0n, 1: RL 1, 2: RL 2
400038 (0025)	Overvoltage alarm output	<i>o v - R</i>	
400039 (0026)	Fuse alarm	<i>F U S E</i>	
400041 (0028)	Alarm heat sink temperature alarm	<i>H E R t</i>	
400042 (0029)	SCR error alarm	<i>S C r</i>	
400043 (002A)	Heater break alarm	<i>H b - R</i>	
400044 (002B)	Auto Gain	<i>A - G R</i>	0 to 1 0: oFF, 1: on

Make Life Easy: Autonics

* Dimensions or specifications on this manual are subject to change and some models may be discontinued without notice.