

# SINGLE AND THREE PHASE THYRISTOR UNITS



- **Intelligent Thyristor Units**
- **EMC and CE Marked**
- **RS485 Comm. STD**
- **Digital Technology**
- **cUL Approved**
- **Diagnostic**

**Fuji Electric Systems Co., Ltd.**

Head office  
6-17, Sanbancho, Chiyoda-ku, Tokyo, 102-0075, Japan  
<http://www.fesys.co.jp/eng>

**Fuji Electric Instruments Co., Ltd.**

Sales Div.  
International Sales Dept.  
No.1, Fuji-machi, Hino-city, Tokyo, 191-8502 Japan  
Phone : 81-42-585-6201,6202  
Fax : 81-42-585-6187  
<http://www.fic-net.co.jp/eng>

# PRODUCT RANGE

## 1 Phase units

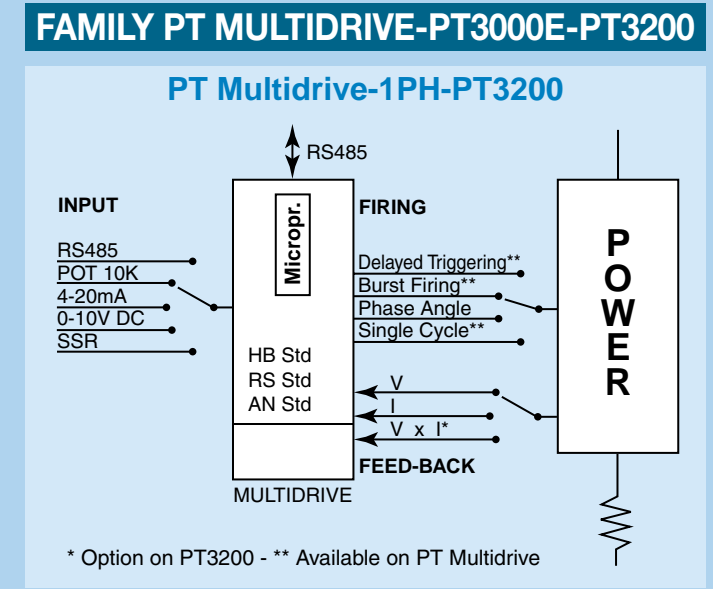
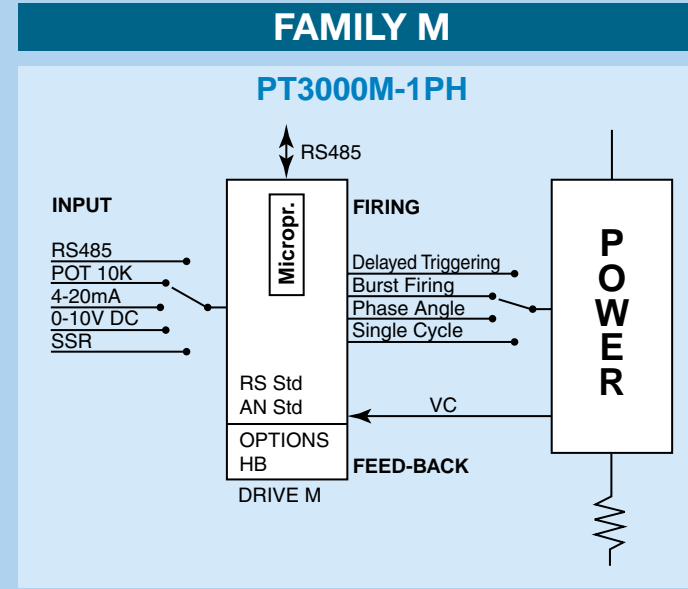
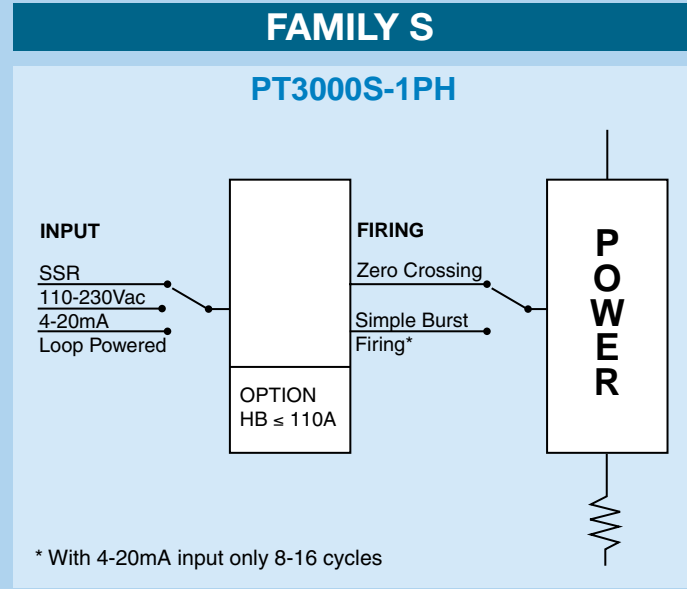
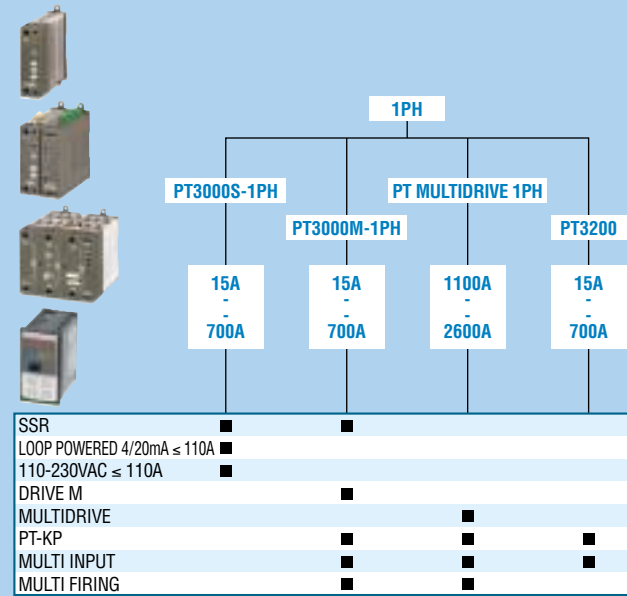

## Two legs switching 3 wire loads

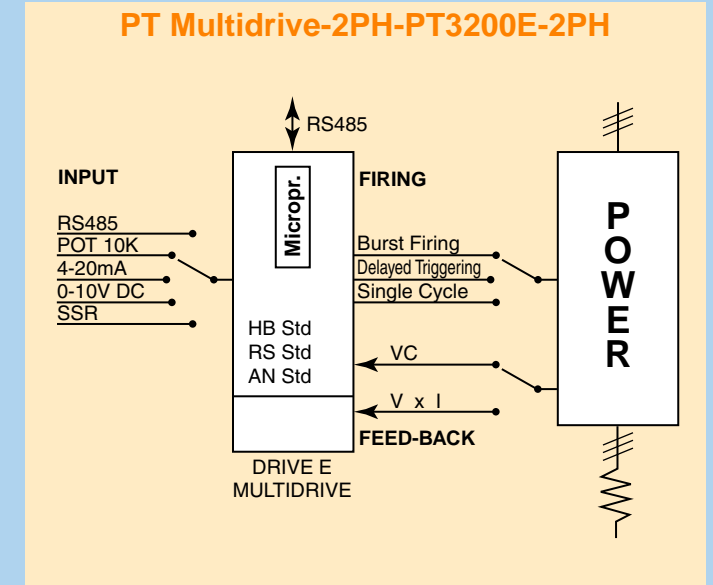
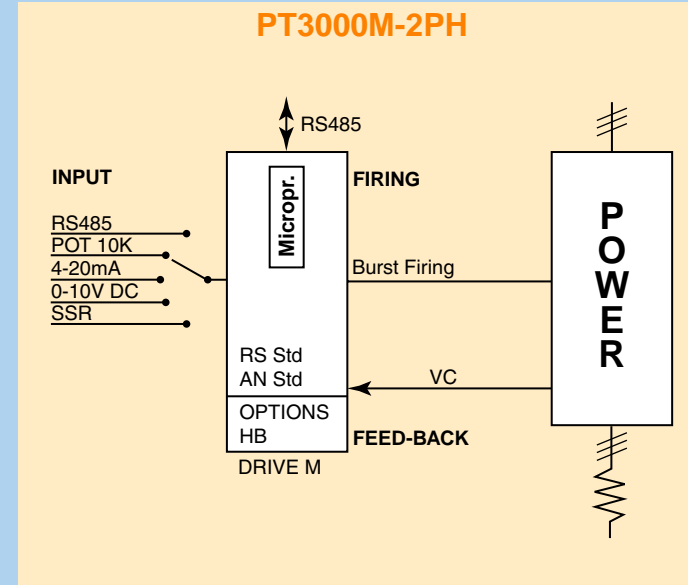
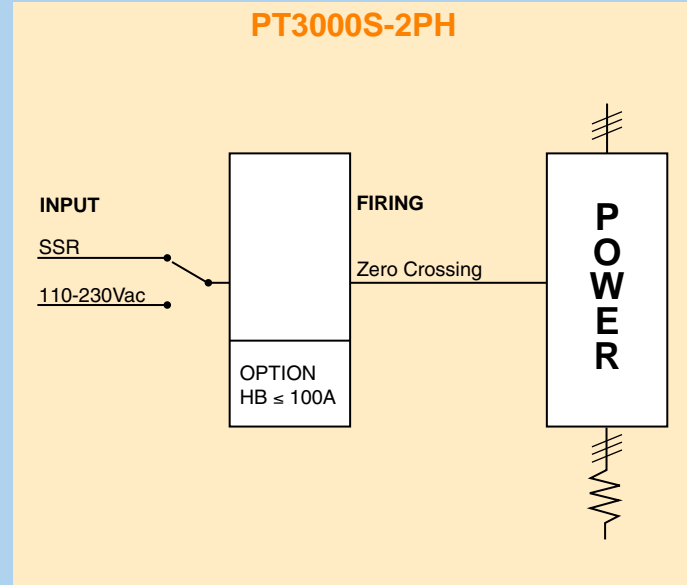
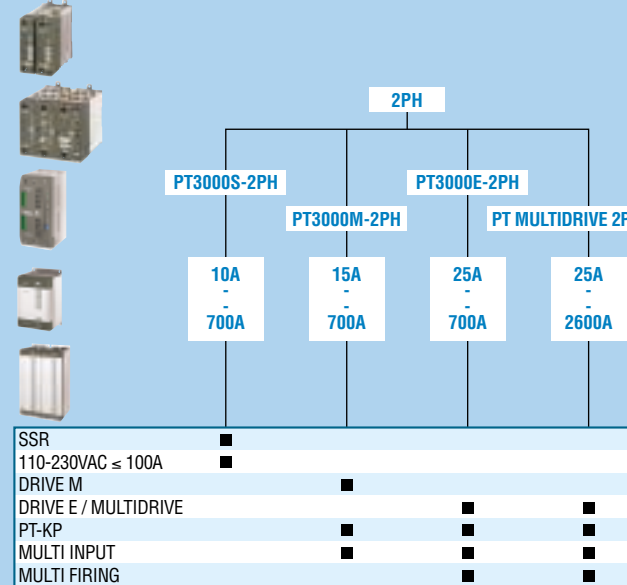

## Three legs switching 3 or 4 wire loads

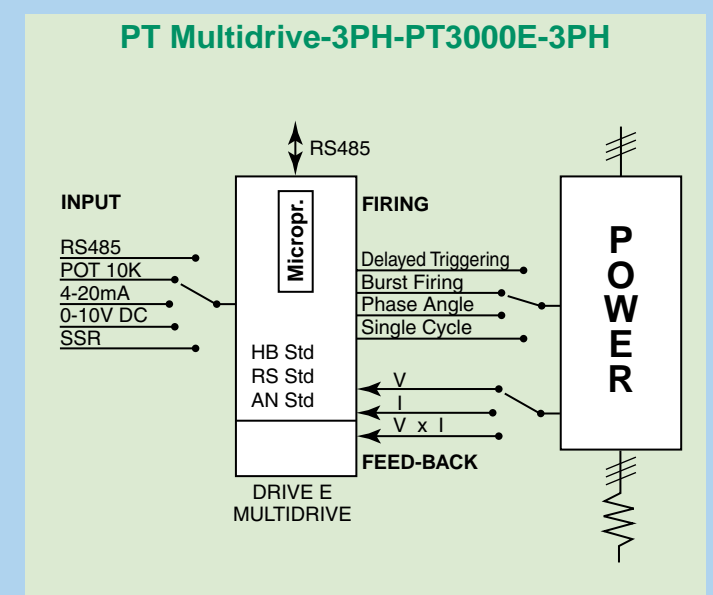
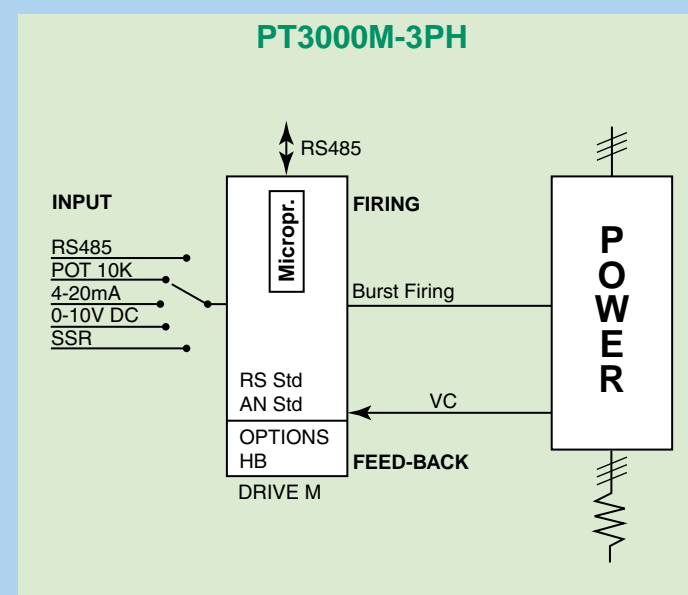
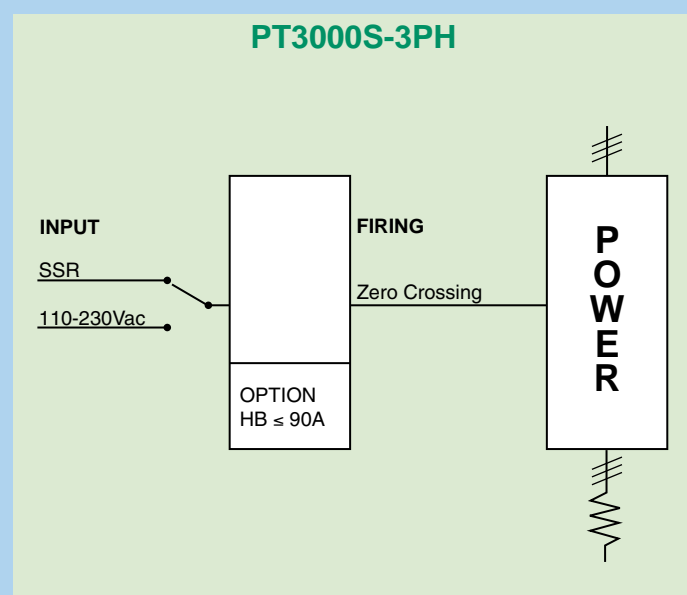
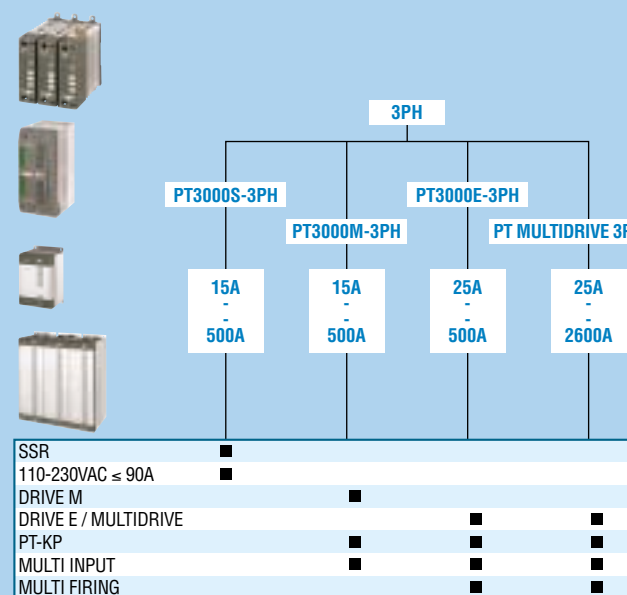

## DIRECT INTEGRATION WITH BUS SYSTEMS & SCADA

Will converse over the most popular Buses: MODBUS, DeviceNet, PROFIBUS.



## APPLICATIONS

FUJI ELECTRIC Thyristor units are rugged and designed for industrial environment. The main applications are:

- extruders
- plastic machinery
- thermoforming machinery
- glass ovens
- electrical furnaces
- print machinery
- drying process
- car industry
- glass industry
- paper industry
- infrared application
- packaging/sealing
- general factory automation
- textile fiber machines
- semiconductor
- food/drink processing
- chemical
- petrochemical

## WHY TO CONTROL THE POWER WITH FUJI ELECTRIC THYRISTOR UNITS!

- Wide product range from 10A to 2.600A single, two and three phase units.
- Save money because there are small steps in nominal current rating (27 sizes from 10A to 2.600A).
- Innovative product range using digital technology also on small units (15A).
- RS485 communication with modbus protocol std on all families with exclusion of PT3000S.
- Configuration semplicity via Frontal KeyPad, external KeyPad or portable PC.
- Possibility to download the suggested software configuration clicking on your application.
- Universal Thyristor unit where is possible to configure all inputs types and firing modes.
- All informations are available through e-mail address: [info@fic-net.co.jp](mailto:info@fic-net.co.jp), where you can find Sales literature, Maintenance Manuals, Configuration software and possibility to ask for enquiries.
- Very efficient Help Desk to solve application problems.
- Remote Service via Internet.

**Just a question: "Where can you have more?"**

## REMOTE SERVICE

If you have a doubt about the configuration of your thyristor unit, contact our Help and Support center that can help you in writing a correct configuration for your application.

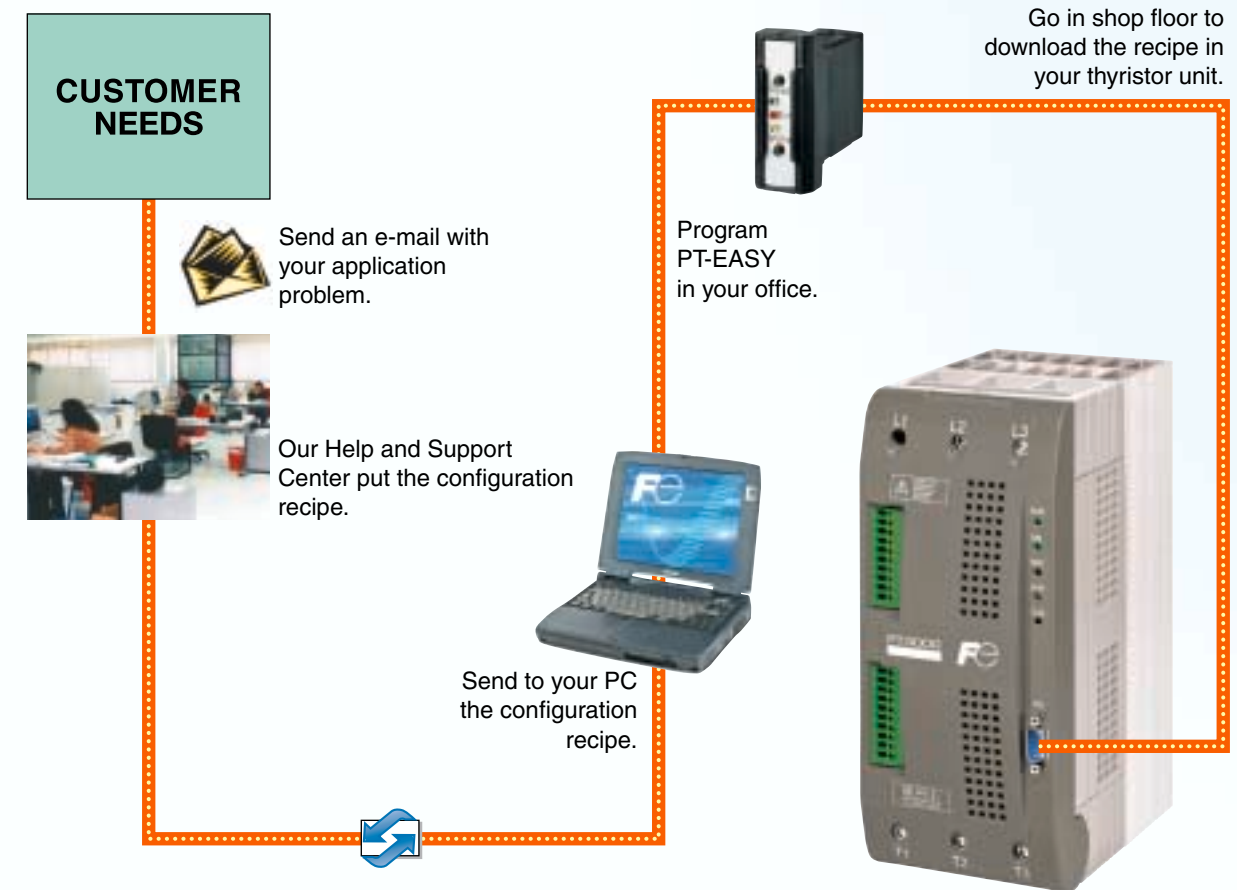

## PT3000 configurator

- Windows based.
- Easy to use with recipe facility. Each Thyristor unit can be configured in a matter of second.
- Possibility to configure the firing mode on line without to power off the unit.
- Look for your application and download the configuration software.

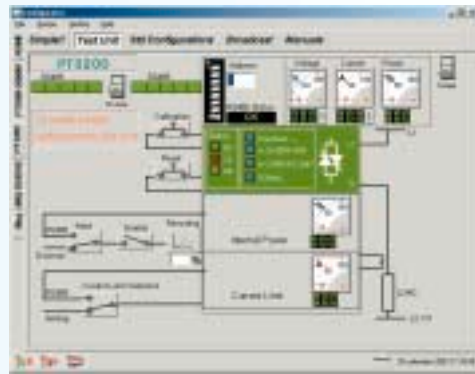

## Glossary

### What is a Thyristor Unit

A Thyristor unit is a semiconductor device which acts as a switch formed by two Silicon Controlled Rectifiers (SCR) in antiparallel. To switch ON the alternating current the input signal will be ON and the Thyristor will switch OFF at first zero crossing voltage with no input signal. The benefits of Thyristor units compared with electromechanical contactors are numerous: no moving parts, no maintenance and capacity to switch very fast. Thyristors are the only solution to control transformers and special loads that change resistance with temperature and with age.

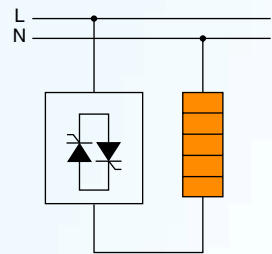

### Terminology

**V:** voltage between any two lines of a 3 phase supply.

**I:** the full circulating current in Thyristor unit.

**P:** total load power.

### Input signal

**SSR:** This input type is a square waveform generated by a temperature controller. Firing of the unit is shown on right page.

**AN:** Analog input 4-20mA/0-10VDC.

**POT:** Potentiometer.

**RS:** Communication Command.

### AC INPUT 110 or 230V

This kind of input allows to drive the Thyristor unit by a 110 or 230Vac signal.

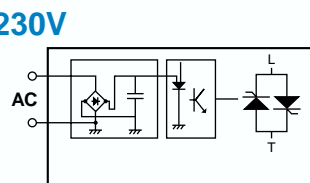

### LP 4-20mA Loop Powered.

The voltage supply for Micro is given by 4-20mA input signal.

With this input is possible to have a simple Burst Firing 8 or 16 Cycles.

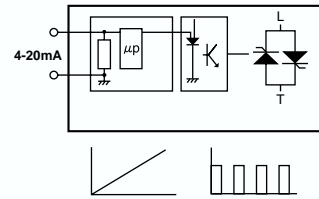

### Feedback

Supply voltage fluctuation changes the power to the load. To overcome this effect the voltage supplied to the load is measured and compared with power demand from controller. The error signal is used to automatically hold the power at demanded level. When the load changes its value it is necessary to use VxI feedback.

### Extra Features

**HB:** Heater Break circuit to diagnose partial or total load failure and short circuit on Thyristors. Thyristors units provide a microprocessor based circuit with automatic setting via a digital input.

**CL:** Current Limit to limit the current to the setted value from 0 to 100% of nominal current. The Current Limit must be used with inductive loads, Molybdenum, Superkanthal, Platinum and Quartz lamp.

**RS:** RS485 two wires serial Communication with MODBUS Protocol. Thyristors units that provide this option, can communicate to a supervisory computer following data: current to the load, HB set, HB status.

**RS:** RS485 two wires serial Communication with MODBUS Protocol. Thyristors units that provide this option, can communicate to a supervisory computer following data: current to the load, HB set, HB status.

### Derating Curve

The nominal current of the units in specification is referred to continuous service at 40°C or 45°C ambient temperature.

For higher temperature multiply the nominal current times derating coefficient "K" below represented.

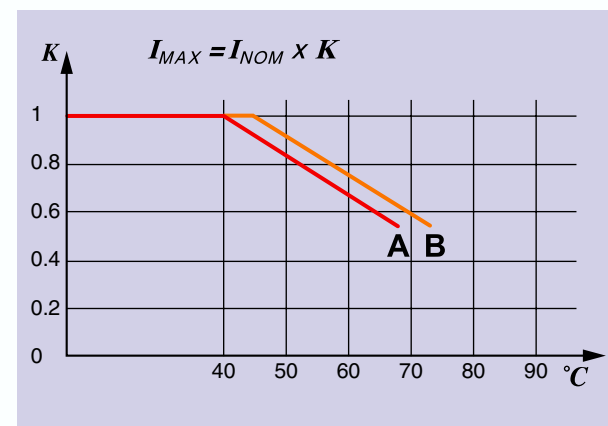

**A:** Use this curve for:  
 PT3000S-1 PH and PT3000M-1PH ≤ 110A  
 PT3000S-2PH and PT3000M-2PH ≤ 100A  
 PT3000S-3PH and PT3000M-3PH ≤ 90A  
**B:** Use this curve for all products not included in the above list.

### Zero Crossing ZC

**ZC** firing mode is used with Logic Output from temperature controllers and the Thyristor operates like a contactor. The Cycle time is performed by temperature controller. Zero Crossing minimizes interferences because the Thyristor unit switches ON-OFF at zero voltage.

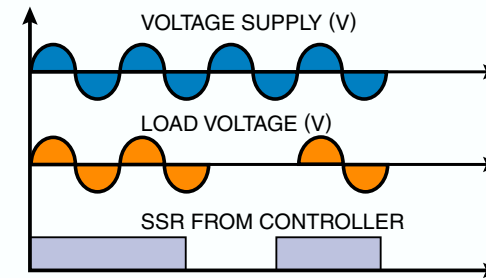

### Burst Firing BF

This firing performed in Digital mode in the Thyristor unit gives a lot of advantages because switches Thyristor at zero voltage crossing without EMC interferences. Analog input is necessary for BF and can be decided how many complete Cycles we want at 50% of power demand. This value can be implemented from 1 to 255 complete Cycles doing the firing less or more fast. When 1 is setted the firing name becomes Single Cycle (see below).

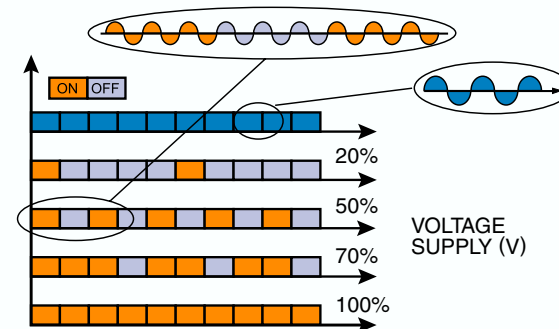

### Single Cycle SC

It's the fastest zero crossing switching method to respect the power demand from a temperature controller or an external signal. At 50% input signal is one cycle ON and one cycle OFF. At 75% is 3 cycles ON and one cycle OFF.

If power demand is 76% the unit performs like for 75% but every time that switches ON the microprocessor divides 76/75 and when the sum of rest is one the unit deliveries one cycle more to the load. With this firing is necessary to have analog input.

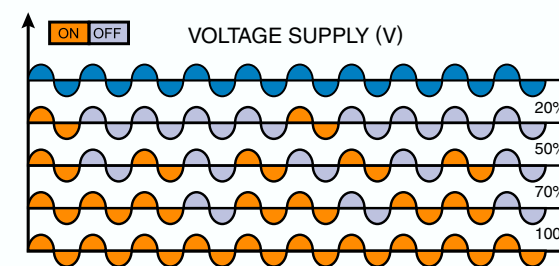

### Delayed Triggering DT

It's used to switch ON-OFF primary of transformers coupled with resistive load on secondary. It's used to prevent inrush surge current when zero voltage switching is used.

The Thyristor unit switches OFF when load voltage is negative and switches ON only when is positive with a setted delay for the first half cycle.

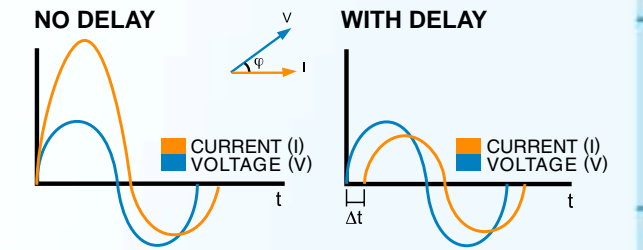

### Phase Angle PA

With Phase Angle is possible to control the power to the load allowing to Thyristor to be in conduction for a variable part of the voltage supply cycle.

The load power can be adjusted from zero to 100% as a function of analog input signal, normally delivered by temperature controller or by potentiometer.

Phase Angle is used with inductive loads.

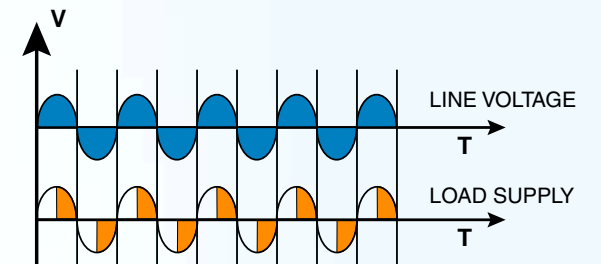

### Soft Start+Burst Firing S+BF

This is an additional feature to Burst Firing. The unit starts in Phase Angle mode with a ramp starting from zero up to full voltage in a presettted and adjustable time.

After which the rest of ON period will be at full conduction.

Soft Start+Burst Firing is used to switch ON small inductive loads to avoid inrush surge current and to reduce at minimum electrical interferences.

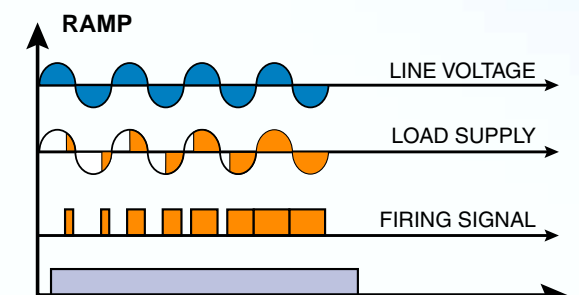

APPLICATION	LOAD TYPE	MODEL	CURRENT	N° of UNITS	CTRL. PHASES	SUGGESTED FIRING MODE FOR YOUR APPLICATION								OTHER FEATURES		SIZING		NOTE
						ZC	SC	BF	S+BF	DT	PA	CL	FEEDBACK	V	I			
	Normal Resistance Infrared medium and long waveform	PT3000S-1PH	700A	1	1	■										V	$\frac{P}{V}$	For general resistance applications with low variations in temperature and age. For low inertia loads use Single Cycle (SC) or Phase Angle (PA).
		PT MULTIDRIVE-1PH	1100-2600A	1	1			■	■				V					
		PT3000M-1PH	700A	1	1			■	■				VC					
		PT3200	700A	1	1							■	V					
	Molibdenum, Tungstenum, Superkanthal, Platinum, Quartz lamp infrared short waveform	PT3200	700A	1	1							■	■	V	V	$\frac{P}{V}$	These resistances change with temperature but have low variations with age. Starting current with cold elements can be 16 times nominal current (superkanthal). Infrared lamp short waveform can reach 8 time nominal current.	
		PT MULTIDRIVE-1PH	1100-2600A	1	1							■	■	V				
	Silicon carbide elements	PT3000M-1PH	700A	1	1			■							V	$\frac{P}{V}$	These resistances change value with temperature and age and value at the end of element life is 4 times the initial value. Constant power regulation is necessary. It's available an algorithm suited to drive in Single Cycle Silicon carbide elements.	
		PT3200	700A	1	1							■	Vxl					
		PT MULTIDRIVE-1PH	1100-2600A	1	1							■	Vxl					
	Transformers and inductances	PT3000M-1PH	700A	1	1					■				VC	V	$\frac{P}{V \cos \phi}$	Transformers and inductors have inrush current on start up. Phase Angle plus Soft Start and current limit are required. To switch ON-OFF the transformer can be used DT firing that automatically switches ON-OFF when current value is zero.	
		PT3200	700A	1	1							■	■	V				
		PT MULTIDRIVE-1PH	1100-2600A	1	1							■		V				
	Normal Resistance	PT3000S-2PH	700A	1	2	■								V	$\frac{P}{1.73V}$	PT3000M-2PH is suitable to control resistive loads with delta or star connection without neutral. With analog input use BF and with SSR input use ZC.		
		PT3000M-2PH	700A	1	2			■					VC					
		PT MULTIDRIVE-2PH	1100-2600A	1	2			■					VC					
	Normal Resistance	PT3000S-3PH	500A	1	3	■								$\frac{V}{1.73}$	$\frac{P}{1.73V}$	Three phase load with star plus neutral connection must be controlled on the three phases.		
		PT3000M-3PH	500A	1	3			■					VC					
		PT MULTIDRIVE-3PH	1100-2600A	1	3			■					VC					
	Silicon carbide elements	PT3000E-3PH	500A	1	3							■		Vxl	V	$\frac{P}{1.73V}$	On three phase silicon carbide elements Vxl feedback is suggested to have a constant power control. This is necessary to compensate resistance change with temperature and age. Resistance value at the end of element life is 4 times the Initial one. It's also necessary a voltage supply that is two times the nominal with new elements. It's also recommended to use SIL Algorithm to use BF firing.	
		PT MULTIDRIVE-3PH	1100-2600A	1	3							■		Vxl				
	Molibdenum, Tungstenum, Superkanthal, Platinum, Quartz lamp infrared short waveform	PT3000E-3PH	500A	1	3							■	■	V	V	$\frac{P}{1.73V}$	These resistances change with temperature but have low variations with age. Start up current with cold elements can be many times nominal current, thus is necessary to use Phase Angle +Current Limit (infrared short waveform).	
		PT MULTIDRIVE-3PH	1100-2600A	1	3							■	■	V				
	Three phase transformer	PT3000E-3PH	500A	1	3							■	■	V	V	$\frac{P}{1.73V \cos \phi}$	Three phase PT Multidrive and PT3000E are specially designed to drive three phase transformers coupled on secondary with normal or special resistive loads.	
		PT MULTIDRIVE-3PH	1100-2600A	1	3							■	■	V				
	Three phase normal load resistance with open delta connection	PT3000S-3PH	500A	1	3	■								V	$\frac{P}{3V}$	Open delta can be driven by three phase unit. With analog input the units will be one Master and two Slaves.		
		PT3000M-3PH	500A	1	3			■					VC					
		PT MULTIDRIVE-3PH	1100-2600A	1	3			■					VC					

FEEDBACK MODE: VC = Voltage compensation, V = Voltage feedback, Vxl = Power feedback.

PRODUCT RANGE		OVERVIEW																								
LOAD TYPE	UNIT TYPE	PT3000S-1PH		PT3000S-2PH		PT3000S-3PH		PT3000M-1PH		PT3000M-2PH		PT3000M-3PH		PT3200		PT3000E-2PH		PT3000E-3PH		PT MULTIDRIVE-1PH		PT MULTIDRIVE-2PH		PT MULTIDRIVE-3PH		
	NOMINAL MAX VOLTAGE POWER SUPPLY	240*-480-600V		480-600V		480-600V		240*-480-600V		480-600V		480-600V		480-600V		480-600V		480-600V		480-600V		480-600V		480-600V		480-600V
INPUT TYPE	CURRENT RANGE	15-700A		10-700A		15-500A		15-700A		15-700A		15-500A		15-700A		25-700A		25-500A		1100-2600A		25-2600A		25-2600A		
	SINGLE PHASE	■						■				■						■				■				
FIRING	3 PHASE LOAD DELTA or STAR NO NEUTRAL			■						■						■				■				■		
	3 PHASE LOAD STAR WITH NEUTRAL					■						■				■				■				■		
FEED BACK	3 PHASE LOAD OPEN DELTA					■						■				■				■				■		
	SSR 0-30VDC	■		■		■		■		■		■		■		■		■		■		■		■		
OPTION	AC INPUT 110 or 230V	up to 110A O		up to 100A O		up to 90A O																				
	4-20mA LOOP POWERED	up to 110A O																								
CONFIG. COMM.	4-20mA							■		■		■		■		■		■		■		■		■		
	0-10VDC							■		■		■		■		■		■		■		■		■		
SIZES	POTENTIOMETER (10k)							■		■		■		■		■		■		■		■		■		
	COMMUNICATION COMMAND							■		■		■		■		■		■		■		■		■		
CURRENT(Amps)	ZERO CROSSING	■		■		■		■		■		■		■		■		■		■		■		■		
	SINGLE CYCLE			■				■		■		■		■		■		■		■		■		■		
MARK	BURST FIRING							■		■		■		■		■		■		■		■		■		
	SOFT START + BURST							■		■		■		■		■		■		■		■		■		
MARK	PHASE ANGLE							■		■		■		■		■		■		■		■		■		
	DELAYED TRIGGERING							■		■		■		■		■		■		■		■		■		
MARK	UNIVERSAL FIRING							■		■		■		■		■		■		■		■		■		
	VOLTAGE DROP COMPENSATION							■		■		■		■		■		■		■		■		■		
MARK	VOLTAGE or CURRENT FEEDBACK (V or I)							■		■		■		■		■		■		■		■		■		
	POWER FEED BACK (V x I)							■		■		■		■		■		■		■		■		■		
MARK	INTERNAL CURRENT LIMIT							■		■		■		■		■		■		■		■		■		
	EXTERNAL CURRENT LIMIT PROFILING							■		■		■		■		■		■		■		■		■		
MARK	HEATER BREAK + SHORT CIRCUIT ON SCR	up to 110A O*		up to 100A O*		up to 90A O*		O		O		O		O		O		O		O		O		O		
	EXTERNAL FUSE AND FUSEHOLDER	≤110A		≤110A		≤90A		≤110A		≤100A		≤90A		≤110A		■		■		■		■		■		
MARK	INTERNAL FUSES	>110A		>110A		>90A		>110A		>100A		>90A		>110A		■		■		■		■		■		
	RS485 WITH MODBUS PROTOCOL							■		■		■		■		■		■		■		■		■		
MARK	CD-KEYPAD CONNECTIVITY							■		■		■		■		■		■		■		■		■		
	FRONTAL KEYPAD							■		■		■		■		■		■		■		■		■		
MARK	PERSONAL COMPUTER PROGRAMMABLE							■		■		■		■		■		■		■		■		■		
	SIZE	SIZE		MARK		SIZE		MARK		SIZE		MARK		SIZE		MARK		SIZE		MARK		SIZE		MARK		
MARK	2x10	S0 CE		S1 CE		S2 CE		S0C cUL/CE		S1C cUL/CE		S2C cUL/CE		S0C cUL/CE		S1C cUL/CE		S2C cUL/CE		S0C cUL/CE		S1C cUL/CE		S2C cUL/CE		
	15	S0 cUL/CE		S1 cUL/CE		S2 cUL/CE		S0C cUL/CE		S1C cUL/CE		S2C cUL/CE		S0C cUL/CE		S1C cUL/CE		S2C cUL/CE		S0C cUL/CE		S1C cUL/CE		S2C cUL/CE		
MARK	25	S0 cUL/CE		S1 cUL/CE		S2 cUL/CE		S0C cUL/CE		S1C cUL/CE		S2C cUL/CE		S0C cUL/CE		S1C cUL/CE		S2C cUL/CE		S0C cUL/CE		S1C cUL/CE		S2C cUL/CE		
	30	S0 cUL/CE		S1 cUL/CE		S2 cUL/CE		S0C cUL/CE		S1C cUL/CE		S2C cUL/CE		S0C cUL/CE		S1C cUL/CE		S2C cUL/CE		S0C cUL/CE		S1C cUL/CE		S2C cUL/CE		
MARK	35	S3 cUL/CE		S4 cUL/CE		S5 cUL/CE		S3C cUL/CE		S4C cUL/CE		S5C cUL/CE		S3C cUL/CE		S4C cUL/CE		S5C cUL/CE		S3C cUL/CE		S4C cUL/CE		S5C cUL/CE		
	45	S3 cUL/CE		S4 cUL/CE		S6 cUL/CE		S3C cUL/CE		S7C cUL/CE		S6C cUL/CE		S3C cUL/CE		S7C cUL/CE		S6C cUL/CE		S3C cUL/CE		S7C cUL/CE		S6C cUL/CE		
MARK	60	S7 cUL/CE		S8 cUL/CE		S7C cUL/CE		S8C cUL/CE		S7C cUL/CE		S8C cUL/CE		S7C cUL/CE		S8C cUL/CE		S7C cUL/CE		S8C cUL/CE		S7C cUL/CE		S8C cUL/CE		
	75	S7 cUL/CE		S5 cUL/CE		S8 cUL/CE		S7C cUL/CE		S8C cUL/CE		S7C cUL/CE		S8C cUL/CE		S7C cUL/CE		S8C cUL/CE		S7C cUL/CE		S8C cUL/CE		S7C cUL/CE		
MARK	90	S7 cUL/CE		S5 cUL/CE		S8 cUL/CE		S7C cUL/CE		S8C cUL/CE		S7C cUL/CE		S8C cUL/CE		S7C cUL/CE		S8C cUL/CE		S7C cUL/CE		S8C cUL/CE		S7C cUL/CE		
	100	S7 cUL/CE		S5 cUL/CE		S8 cUL/CE		S7C cUL/CE		S8C cUL/CE		S7C cUL/CE		S8C cUL/CE		S7C cUL/CE		S8C cUL/CE		S7C cUL/CE		S8C cUL/CE		S7C cUL/CE		
MARK	110	S8 cUL/CE		S9 cUL/CE		S11 cUL/CE		S8C cUL/CE		S9 cUL/CE		S11 cUL/CE		S8C cUL/CE		S9 cUL/CE		S11 cUL/CE		S8C cUL/CE		S9 cUL/CE		S11 cUL/CE		
	125	S8 cUL/CE		S9 cUL/CE		S11 cUL/CE		S8C cUL/CE		S9 cUL/CE		S11 cUL/CE		S8C cUL/CE		S9 cUL/CE		S11 cUL/CE		S8C cUL/CE		S9 cUL/CE		S11 cUL/CE		
MARK	150	S9 cUL/CE		S9 cUL/CE		S11 cUL/CE		S9 cUL/CE		S9 cUL/CE		S10 cUL/CE		S9 cUL/CE		S11 cUL/CE		S9 cUL/CE		S11 cUL/CE		S9 cUL/CE		S11 cUL/CE		
	200	S9 cUL/CE		S10 cUL/CE		S13 cUL/CE		S9 cUL/CE		S10 cUL/CE		S13 cUL/CE		S9 cUL/CE		S11 cUL/CE		S9 cUL/CE		S11 cUL/CE		S9 cUL/CE		S11 cUL/CE		
MARK	225	S9 cUL/CE		S10 cUL/CE		S13 cUL/CE		S9 cUL/CE		S10 cUL/CE		S13 cUL/CE		S9 cUL/CE		S11 cUL/CE		S9 cUL/CE		S11 cUL/CE		S9 cUL/CE		S11 cUL/CE		
	275	S9 cUL/CE		S14 UL/CE		S13 cUL/CE		S9 cUL/CE		S10 cUL/CE		S14 cUL/CE		S9 cUL/CE		S11 cUL/CE		S9 cUL/CE		S11 cUL/CE		S9 cUL/CE		S11 cUL/CE		
MARK	300	S12 cUL/CE		S14 cUL/CE		S14 cUL/CE		S12 cUL/CE		S14 cUL/CE		S14 cUL/CE		S12 cUL/CE		S14 cUL/CE		S14 cUL/CE		S12 cUL/CE		S14 cUL/CE		S14 cUL/CE		
	350	S12 cUL/CE		S14 cUL/CE		S14 cUL/CE		S12 cUL/CE		S14 cUL/CE		S14 cUL/CE		S12 cUL/CE		S14 cUL/CE		S14 cUL/CE		S12 cUL/CE		S14 cUL/CE		S14 cUL/CE		
MARK	400	S12 cUL/CE		S14 cUL/CE		S14 cUL/CE		S12 cUL/CE		S14 cUL/CE		S14 cUL/CE		S12 cUL/CE		S14 cUL/CE		S14 cUL/CE		S12 cUL/CE		S14 cUL/CE		S14 cUL/CE		
	450	S12 cUL/CE		S14 UL/CE		S14 cUL/CE		S12 cUL/CE		S14 cUL/CE		S14 cUL/CE		S12 cUL/CE		S14 cUL/CE		S14 cUL/CE		S12 cUL/CE		S14 cUL/CE		S14 cUL/CE		
MARK	500	S12 cUL/CE		S14 cUL/CE		S14 cUL/CE		S12 cUL/CE		S14 cUL/CE		S14 cUL/CE		S12 cUL/CE		S14 cUL/CE		S14 cUL/CE		S12 cUL/CE		S14 cUL/CE		S14 cUL/CE		
	600	S12 cUL/CE		S14 cUL/CE		S14 cUL/CE		S12 cUL/CE		S14 cUL/CE		S14 cUL/CE		S12 cUL/CE		S14 cUL/CE		S14 cUL/CE		S12 cUL/CE		S14 cUL/CE		S14 cUL/CE		
MARK	700	S12 UL/CE		S14 UL/CE		S14 cUL/CE		S12 cUL/CE		S14 cUL/CE		S14 cUL/CE		S12 cUL/CE		S14 cUL/CE		S14 cUL/CE		S12 cUL/CE		S14 cUL/CE		S14 cUL/CE		
	1100	S12 UL/CE		S14 UL/CE		S14 cUL/CE		S12 cUL/CE		S14 cUL/CE		S14 cUL/CE		S12 cUL/CE		S14 cUL/CE		S14 cUL/CE		S12 cUL/CE		S14 cUL/CE		S14 cUL/CE		
MARK	1600	S15 CE		S16 CE		S17 CE		S15 CE		S16 CE		S17 CE		S15 CE		S16 CE		S17 CE		S15 CE		S16 CE		S17 CE		
	2100	S15 CE		S16 CE		S17 CE		S15 CE		S16 CE		S17 CE		S15 CE		S16 CE		S17 CE		S15 CE		S16 CE		S17 CE		
MARK	2600	S15 CE		S16 CE		S17 CE		S15 CE		S16 CE		S17 CE		S15 CE		S16 CE		S17 CE		S15 CE		S16 CE		S17 CE		

NOTES: \* no cUL Mark Note: 1 strengthened ventilation system in cUL version ■ = Standard O = option

## SIZES AND DIMENSIONS OF FUJI ELECTRIC PRODUCT RANGE

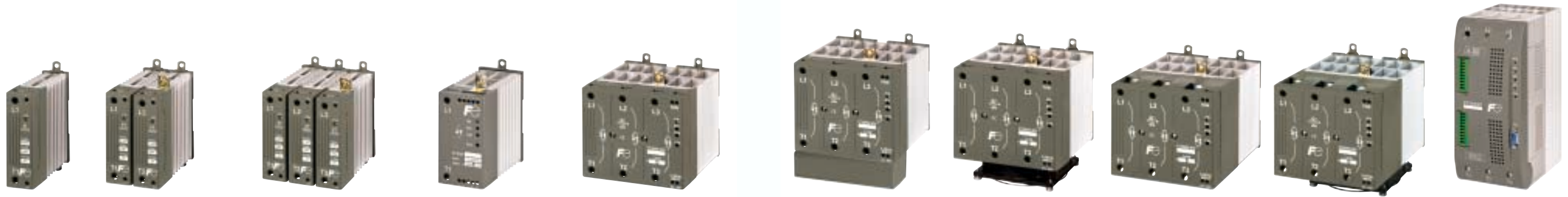

SIZE	S0	S1	S2	S3	S4	S5	S6	S7	S8	S9
Width	30	60	92	52	117	117	117	117	117	116
Height	120	120	145	120	120	150	138	120	138	316
Depth	120	120	120	120	123	123(159)	123	159	159	187



SIZE	S0C	S1C	S2C	S3C	S4C	S6C	S7C	S8C	S10C
Width	63	95	123	85	148	148	148	148	116
Height	120	120	145	120	120	138	120	138	350
Depth	120	120	120	120	123	123	159	159	220



SIZE	S11	S12	S13	S14	S15	S16	S17
Width	137	137	262	262	See next page	See next page	See next page
Height	440	520	440	520			
Depth	270	270	270	270			

## INDUSTRIAL THYRISTOR PACKAGE

### PT1000 Thyristor Unit

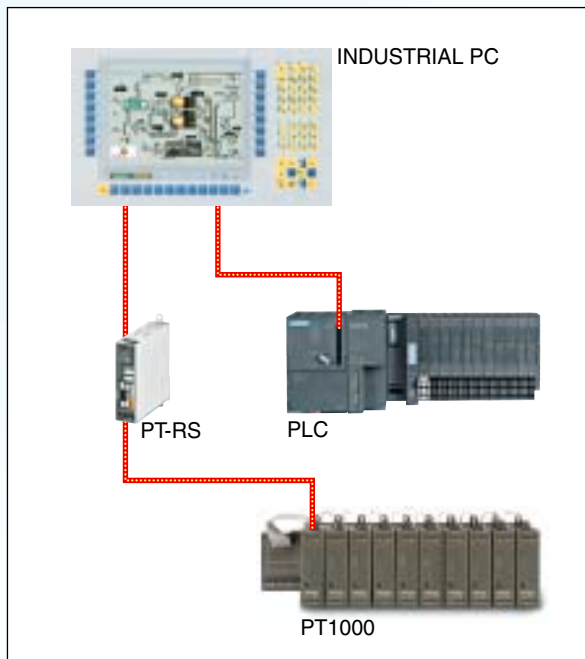
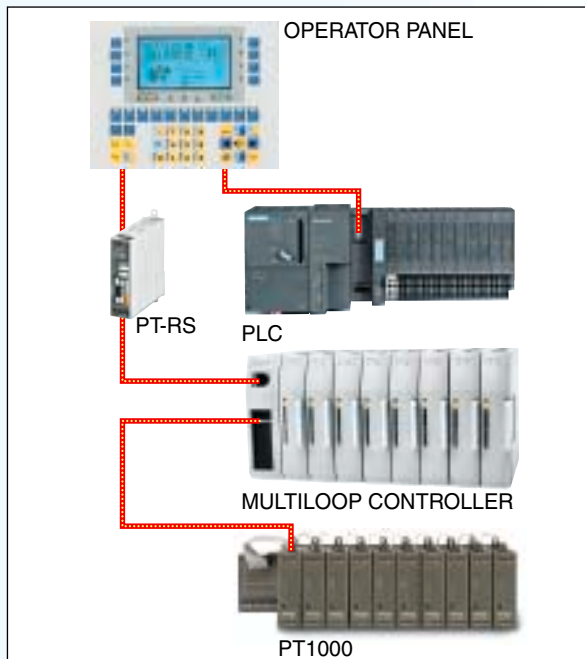

The Thyristor units can be divided in two categories. General purpose Thyristor units suitable to be used in all processes and "industrial package", like **PT1000**, dedicated to a specific process. **PT1000** is normally used where there are many zones: coextrusion, blow moulding and thermoforming machineries. Target and typical architecture are represented in this page.

- Dramatic reduction of wiring. The connection between HMI and Thyristor Units is done via RS485 comm..
- Wiring between Thyristor Units is done with flat cables and connectors to avoid to make traditional wiring for auxiliary voltage supply, RS485 comm. and HB alarm. Customer has to wire only input/output power cables.
- All commands and informations are available on RS485 like load status and current value. It's also possible to set the power output of Thyristor unit using analog input or digital command on comm. port.

### Specification

- **PT1000** is a digital and universal Thyristor unit configurable via serial communication port for different types of input and firing modes.
- **RS485** communication and **HB** alarm are standard features. Current transformer is included in 3.5A model, for other models is mounted outside.
- Universal input and firing are customer configurable via serial port. Single Cycle, Burst Firing and Phase Angle can be configured adding also Soft Start facility. The change from one to the other firing can be done via serial port with **PT1000** in ON condition.
- Current rating: 3.5-15-25-35-45-60-90-110A
- DIN rail mounting side by side.

## MULTIDRIVE 1-2-3 PHASE THYRISTOR UNIT FROM 1100 TO 2600A

### General Description



- **MULTIDRIVE** is a full digital and universal Thyristor unit based on a very powerful dedicated micro configurable via serial communication port for all inputs, firing modes, feedback modes and load types.
- Suitable to drive resistive and transformer loads.
- Power feedback.
- Frontal Keypad standard to configure all the Internal functions and parameters.
- Universal Input signal with automatic zero/span calibration.
- Universal Firing modes, customer configurable via Keypad or communication port.
- Unbalanced load and Heater Break Alarm.
- RS485 port. Modbus.
- Comply with EMC and CE

### ORDERING CODE

Controlled Phases	Current [A]	Supply voltage [V]	Load connections	Auxiliary voltage [V]	Load type	1-3PH Firing Mode
1PH	1100A	480V	3D3 Delta	110V	RES Resistive	SC (Single Cycle)
2PH	1600A	600V	3D6 Open Delta	230V	IND Inductive	BF (Burst Firing)
3PH	2100A		3S Star		TRA Transformer	DT (Delayed Triggering)
	2600A		4S Star + neutral			PA (Phase Angle)

2 PH Firing Mode	Feedback mode	Main input	Second input	External curr. profil.	Retransmission	Standard Features
BF (Burst Firing)	W Power	SSR	SSR	SSR	V10 Voltage 0-10V	HB (Heater Break Alarm)
DT (Delayed Triggering)	V Voltage	0-10V	0-10V	0-10V	I10 Current 0-10V	UL (Max Unbalanced Load std)
	I Current	4-20mA	4-20mA	4-20mA	W10 Power 0-10V	FF (Fuses fail microswitch)
	EX External 0-10V	10KPot	10KPot	10KPot		RS (RS485 Modbus protocol)
		Comm	Comm	Comm		
		CD-KP (Keypad)	CD-KP(keypad)	CD-KP(keypad)		

### DIMENSIONS

Model	I Max [A] Ta=40°C	V Max SCR PRV [V]	SCR	Dimensions 1PH W x H x D [mm]	Dimensions 2-3PH W x H x D [mm]	Power Loss [kW]	Weight [kg]	Draw N.
TAF1100	1100	1600	CDT804	262x720x410	500x720x410	3,5	55	4141
TAF1600	1600	1600	CDT1003	262x920x410	570x920x410	5,8	82	4110
TAF2100	2100	1600	CDT636	300x920x520	736x920x520	7,2	82	4143
TAF2600	2600	1600	CDT738	300x1040x520	300x1040x515	9	165	4104

## AUXILIARY UNITS



### ■ PT-RS

Compact and smart communication converter. Input **RS232**. Output **RS485** or **422**. **RS232** connection via a 9 pin connector on front unit. **RS485** or **422** via screw terminals. This converter can be used to interface a computer with communicating Thyristor Units.



### ■ Field Bus Modules

**TU-PB** can be used to convert RS485 in PROFIBUS DP. **TU-DN** can be used to convert RS485 in DEVICENET.



### ■ PXR Temperature controllers

The digital temperature controller that incorporates a wealth of control functions plays a significant role in several fields. This PXR controller features fuzzy control that can withstand the adverse effects of overshoot and external disturbances. This makes it the controller best suited to severe temperature control conditions. In addition to providing a waterproof structure, this controller offers you a broad selection of sizes, thereby allowing you to select the size best suited to your area of application.



### ■ PT EASY

This is a memory support tool used by maintenance personnel on the shop floor, which enables the user to clone the configuration of one Thyristor unit and paste it into another. The **PT-EASY** is very simple, with one push button to upload the configuration (Read) and another to download the stored configuration (Write). The **PT-EASY** can be used with all Fuji Electric Thyristor units that have the communications facility.



### ■ Auto/Manual Station

The **PT-AM Auto Manual Station** can be used to deliver the input signal to Thyristor Unit. The unit has a frontal indicator of output and up-down pushbuttons. Auto/Manual switch with bumpless procedure is standard.



### ■ Current transformers for Heater Break option

The external current transformer is used on one phase units up to 110A, two phase units up to 100A, three phase units up to 90A. The dimensions are always 38x48x20mm (WxHxD). For units over the above current the transformer is internal to the unit.

## KEYPAD FOR THYRISTOR UNIT

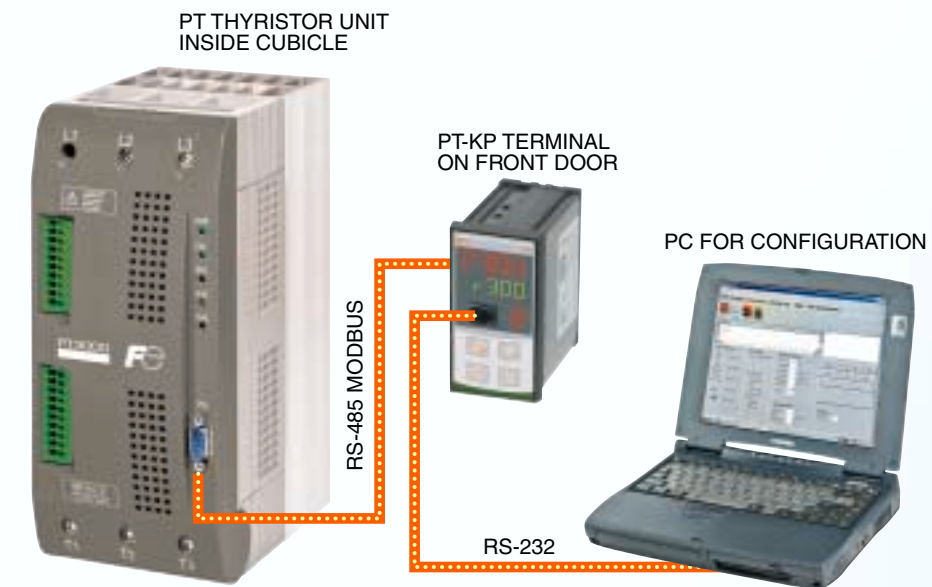

### General Description

- Local/Remote facility
- Set point ramp up/down
- Scroll selection of:
  - Set point power
  - Power read out
  - Current
  - Voltage
- Display indication for:
  - Heater Break alarm
  - SCR short circuit
- Retransmission (4-20mA or 0-10V) of one of these parameters: power, current, voltage.
- Dimensions 48x96x92mm (WxHxD).

PT-KP is designed to give two access levels.

- First Level Access: the operator is able to view the power, current and voltage levels as well as set the power when the PT-KP is in Local Mode. At this level the password function is disabled to prevent accidental parameter changes by unauthorised personnel.
- Second level access: By connecting a PC to the RS232 port, located on the front of the PT-KP, it is possible to access all parameters of the Thyristor Unit using the free downloadable Configuration Software. Configuration changes can be made interactively, without powering down the unit, removing the need to open the cabinet or to stop the process.

## CLONE FACILITY USING PT-EASY

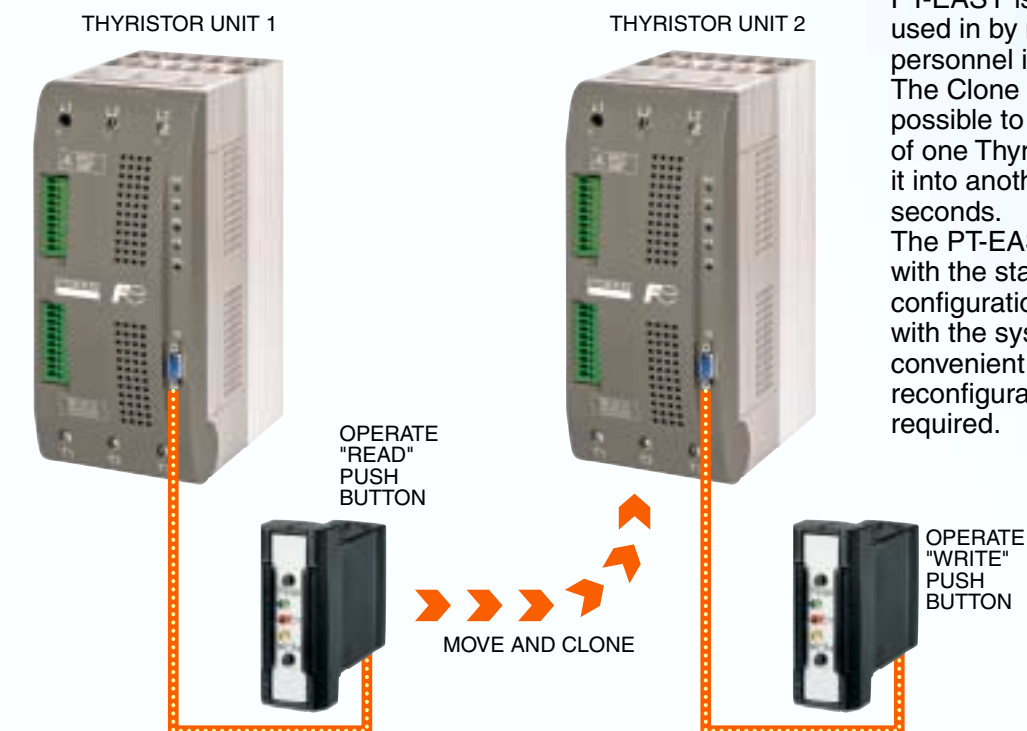

PT-EASY is a Memory Support used in by maintenance personnel in the shop floor. The Clone Facility makes it possible to copy the configuration of one Thyristor Unit and paste it into another in a matter of seconds. The PT-EASY can be loaded with the standard unit operating configuration and stored together with the system drawings in a convenient place, enabling unit reconfiguration within seconds if required.

# FUSES AND FUSEHOLDERS

High speed fuses for semi-conductor protection.



SIZE	F0	F1	F2	F3
Width	17	26	35	37
Height	80	110	125	150
Depth	60	77	77	107

Fuse & Fuseholder Selection TAB		Models		PT1000 PT3000S PT3000M PT3200		PT3000S-2PH PT3000M-2PH		PT3000S-3PH PT3000M-3PH		PT3000E		PT MULTI DRIVE	
		(1 off)	(each phase)	(3 off)	(each phase)	(3 off)	(each phase)	(each phase)	(each phase)	(each phase)	(each phase)	(each phase)	
Current	Size	Fuse + Fuseholder	Spare fuses	Fuse + Fuseholder	Spare fuses	Fuse + Fuseholder	Spare fuses	Fuse + Fuseholder	Spare fuses	Spare fuses	Spare fuses	Spare fuses	Spare fuses
3,5A	F0	FFH1038/8A	FU1038/8A	FFH1038/16A	FU1038/16A	FFH1038/16A	FU1038/16A	FFH1038/16A	FU1038/16A				
2x10A	F0	FFH1038/16A	FU1038/16A	FFH1038/16A	FU1038/16A	FFH1038/16A	FU1038/16A	FFH1038/16A	FU1038/16A				
15A	F0	FFH1038/16A	FU1038/16A	FFH1038/32A	FU1038/32A	FFH1038/32A	FU1038/32A			FU50FE	FU50FE	FU50FE	FU50FE
25A	F0	FFH1038/32A	FU1038/32A										
30A	F1							FFH1451/40A	FU1451/40A				
35A	F1	FFH1451/40A	FU1451/40A	FFH1451/40A	FU1451/40A	FFH1451/40A	FU1451/40A			FU63FE	FU63FE		
45A	F1	FFH1451/50A	FU1451/50A	FFH1451/63A	FU1451/63A	FFH1451/50A	FU1451/50A			FU80FE	FU80FE	FU80FE	FU80FE
60A	F2	FFH2258/80A	FU2258/80A			FFH2258/80A	FU2258/80A						
75A	F2			FFH2258/100A	FU2258/100A	FFH2258/100A	FU2258/100A			FU100FE	FU100FE	FU100FE	FU100FE
90A	F2	FFH2258/125A	FU2258/125A			FFH2258/125A	FU2258/125A						
100A	F2			FFH2258/125A	FU2258/125A					FU160FEE	FU2X80FE	FU160FEE	FU160FEE
110A	F3	FFHPSI27/160A	FU2760/160A										
125A	IF	IF	FU200FEE	IF	FU200FEE	IF	FU2X100FE	FU200FEE	FU2x100FE	FU200FEE	FU200FEE	FU200FEE	FU200FEE
150A	IF	IF	FUURB250 or FU200FEE	IF	FUURB250 or FU200FEE	IF	FU2X100FE	FUURB250 or FU200FEE	FU2x100FE	FUURB250 or FU200FEE	FUURB250 or FU200FEE	FUURB250 or FU200FEE	FUURB250 or FU200FEE
200A	IF	IF	FUURB315	IF	FUURB315			FUURB315					
225A	IF							FUURB315 or 2xFEE160		FUURB315 or 2xFEE160	FUURB315 or 2xFEE160	FUURB315 or 2xFEE160	FUURB315 or 2xFEE160
275A	IF			IF	FUURB315 or 2xFEE160			FUURB315 or 2xFEE160		FUURB315 or 2xFEE160	FUURB315 or 2xFEE160	FUURB315 or 2xFEE160	FUURB315 or 2xFEE160
300A	IF	IF	FU350FM										
350A	IF												
400A	IF	IF	FU550FMM	IF	FU550FMM	IF	FU550FMM	FU550FMM	FU550FMM	FU550FMM	FU550FMM	FU550FMM	FU550FMM
450A	IF			IF	2xFU315FM	IF	2xFU315FM	2xFU315FM	2xFU315FM	2xFU315FM	2xFU315FM	2xFU315FM	2xFU315FM
500A	IF	IF	FU700FMM	IF	2xFU315FM	IF	2xFU315FM	2xFU315FM	2xFU315FM	2xFU315FM	2xFU315FM	2xFU315FM	2xFU315FM
600A	IF	IF	2xFU450FMM	IF	2xFU450FMM			2xFU450FMM		2xFU450FMM	2xFU450FMM	2xFU450FMM	2xFU450FMM
700A	IF	IF	2xFU450FMM	IF	2xFU450FMM			2xFU450FMM		2xFU450FMM	2xFU450FMM	2xFU450FMM	2xFU450FMM

Fuse & Fuseholder Selection TAB		Models cULus approved		PT1000 PT3000S PT3000M PT3200		PT3000S-2PH PT3000M-2PH		PT3000S-3PH PT3000M-3PH		PT3000E		PT MULTI DRIVE	
		(1 off)	(each phase)	(3 off)	(each phase)	(3 off)	(each phase)	(each phase)	(each phase)	(each phase)	(each phase)	(each phase)	
Current	Size	Fuse + Fuseholder	Spare fuses	Fuse + Fuseholder	Spare fuses	Fuse + Fuseholder	Spare fuses	Fuse + Fuseholder	Spare fuses	Spare fuses	Spare fuses	Spare fuses	Spare fuses
3,5A	F0	FFH1038/8A-UL	FU1038/8A-UL	FFH1038/16A-UL	FU1038/16A-UL	FFH1038/16A-UL	FU1038/16A-UL	FFH1038/16A-UL	FU1038/16A-UL				
2x10A	F0	FFH1038/16A-UL	FU1038/16A-UL	FFH1038/16A-UL	FU1038/16A-UL	FFH1038/16A-UL	FU1038/16A-UL	FFH1038/16A-UL	FU1038/16A-UL				
15A	F0	FFH1038/16A-UL	FU1038/16A-UL	FFH1038/32A-UL	FU1038/32A-UL	FFH1038/32A-UL	FU1038/32A-UL			FU50FE	FU50FE	FU50FE	FU50FE
25A	F0	FFH1038/32A-UL	FU1038/32A-UL										
30A	F1							FFH1451/40A-UL	FU1451/40A-UL				
35A	F1	FFH1451/40A-UL	FU1451/40A-UL	FFH1451/40A-UL	FU1451/40A-UL	FFH1451/40A-UL	FU1451/40A-UL			FU63FE	FU63FE		
45A	F1	FFH1451/50A-UL	FU1451/50A-UL	FFH1451/63A-UL	FU1451/63A-UL	FFH1451/50A-UL	FU1451/50A-UL			FU80FE	FU80FE	FU80FE	FU80FE
60A	F2	FFH2258/80A-UL	FU2258/80A-UL			FFH2258/80A-UL	FU2258/80A-UL						
75A	F3			FFHPSI27/100A-UL	FU2760/100A-UL	FFHPSI27/100A-UL	FU2760/100A-UL			FU100FE	FU100FE	FU100FE	FU100FE
90A	F3	FFHPSI27/125A-UL	FU2760/125A-UL			FFHPSI27/125A-UL	FU2760/125A-UL						
100A	F3			FFHPSI27/160A-UL	FU2760/160A-UL					FU160FEE	FU2X80FE	FU160FEE	FU160FEE
110A	F3	FFHPSI27/160A-UL	FU2760/160A-UL										
125A	IF	IF	FU200FEE	IF	FU200FEE	IF	FU2X100FE	FU200FEE	FU2x100FE	FU200FEE	FU200FEE	FU200FEE	FU200FEE
150A	IF	IF	FUURB250 or FU200FEE	IF	FUURB250 or FU200FEE	IF	FU2X100FE	FUURB250 or FU200FEE	FU2x100FE	FUURB250 or FU200FEE	FUURB250 or FU200FEE	FUURB250 or FU200FEE	FUURB250 or FU200FEE
200A	IF	IF	FUURB315	IF	FUURB315			FUURB315					
225A	IF							FUURB315 or 2xFEE160		FUURB315 or 2xFEE160	FUURB315 or 2xFEE160	FUURB315 or 2xFEE160	FUURB315 or 2xFEE160
275A	IF			IF	FUURB315 or 2xFEE160			FUURB315 or 2xFEE160		FUURB315 or 2xFEE160	FUURB315 or 2xFEE160	FUURB315 or 2xFEE160	FUURB315 or 2xFEE160
300A	IF	IF	FU350FM										
350A	IF												
400A	IF	IF	FU550FMM	IF	FU550FMM	IF	FU550FMM	FU550FMM	FU550FMM	FU550FMM	FU550FMM	FU550FMM	FU550FMM
450A	IF			IF	2xFU315FM	IF	2xFU315FM	2xFU315FM	2xFU315FM	2xFU315FM	2xFU315FM	2xFU315FM	2xFU315FM
500A	IF	IF	FU700FMM	IF	2xFU315FM	IF	2xFU315FM	2xFU315FM	2xFU315FM	2xFU315FM	2xFU315FM	2xFU315FM	2xFU315FM
600A	IF	IF	2xFU450FMM	IF	2xFU450FMM			2xFU450FMM		2xFU450FMM	2xFU450FMM	2xFU450FMM	2xFU450FMM
700A	IF	IF	2xFU450FMM	IF	2xFU450FMM			2xFU450FMM		2xFU450FMM	2xFU450FMM	2xFU450FMM	2xFU450FMM

NOTES: IF = internal fuses, FFH = external fuse+fuseholder.

In accordance with our policy of continuous improvement, FUJI ELECTRIC reserves the right to change specifications from those shown in this document.

... Where adding expert to your staff is easy as point and click



Our solution oriented web-site allows you to collect all informations for our products range.

- Temperature Controllers.
- Multiloop Controllers.
- Recorders.
- Pressure Transmitters.
- Flowmeters.
- Gas Analyzers.

... We guarantee your satisfaction and we help you to save time