

Z Series Digital Temperature Controller
Micro Controller PXR Series



[1] Features



PXR9
[96X96mm]

PXR5
[48X96mm]

PXR7
[72X72mm]

PXR4
[48X48mm]

PXR3
[24X48mm]

option →

- RS485 communication
- Digital input
- Alarm 2 points
- Heater burnout
- Heating/cooling control function
- Ramp/soak function
- Re-Transmission

(Except PXR3)

Large LED display

Further enlarged



PXW4 (Existing model)



PXR4

Character height	PXR3	PXR4 PXR5	PXR7	PXR9
PV display	11mm	13mm	17mm	20mm
SV display	11mm	11mm	12mm	12mm

Visibility excellent
even at a distance!

Short depth

More compact

Helpful for designing of small and thin panels and equipments.

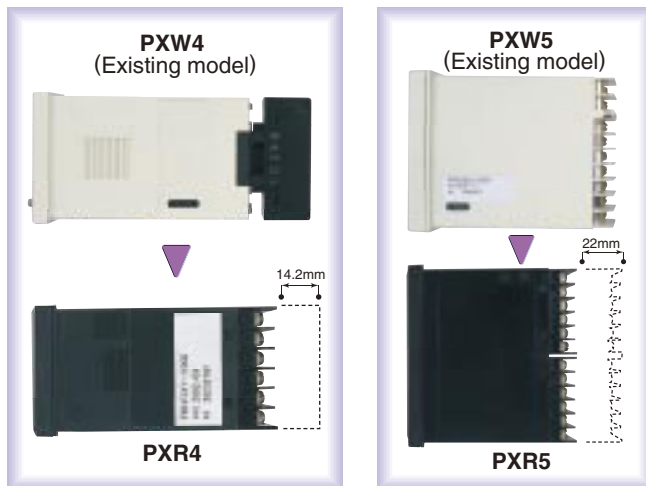

contents

Temperature controller PXR

- Features 2
- Products range..... 6
- Ordering code..... 7
- Specifications..... 8
- Outline diagram/panel-cut 11
- Connection diagram..... 12
- Functions..... 14
- Sensor fault operation..... 17
- Table of parameters..... 18

Temperature controller PXW,PXZ,PXV

- Features 22
- Ordering code..... 23
- Specifications 24
- Outline diagram/panel-cut..... 26
- Connection diagram..... 27
- Socket outline diagram..... 28
- Table of alarm code..... 29
- Table of parameters..... 30

Digital thermostat PAS3

- Specifications..... 32
- Outline diagram/panel-cut 33
- Connection diagram..... 33

Temperature controller list

- PX series..... 34

Manual operation (standard)

Available to control MV output with Manual Mode.



Except for PXR3

Front waterproof structure (standard)

The front display and operation section is waterproof in conformity with NEMA-4X:IP66. So the front panel is washable with water. (Use of the attached packing for waterproof is required.)



DIN rail mounting (PXR3)



Mountable to a DIN rail using the DIN rail mounting adapter available at option. With this adapter, also mountable to a wall.

Terminal block protecting cover (PXR4)



The terminal block can be protected with the terminal cover available at option.

Diversified control and tuning functions (standard)

Simple ON/OFF control, PID with auto tuning, fuzzy PID with auto tuning and PID with self-tuning are standard with PXR.

● Self-tuning

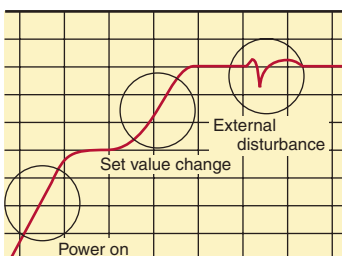

At power on, changing a set value or during external disturbance, tuning is made automatically so that the PID parameters are reoptimized

Note: For some objects to control, PID values could not be optimized.

● Fuzzy control

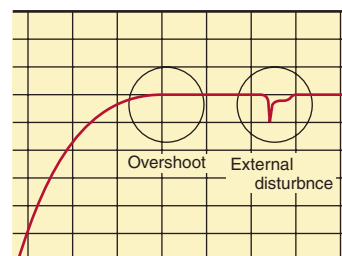

Suppresses the overshoot without wasting start up time. Also, quickly reverts to set points at the event of external disturbances

[1] Features

Various functions and abundant options

More functions

Standard equipment

- 1 **Diverse control and tuning functions** ... Capable of covering various controls within a wide range from simple ON/OFF control to fuzzy PID control.
- 2 **Front waterproof structure (conforming with NEMA-4X:IP66)** ... The front panel is washable with water.

Optional functions

- 1 **Re-transmission output in 4 to 20 mA DC** ... PV (process value), SV (set value) and MV (manipulated output value) can be transferred to other measuring instrument.
- 2 **8-step ramp/soak function** ... Allows use as a simple programmable controller with a set value program.
- 3 **RS-485 communication** ... Selectable between MODBUS protocol and Z-ASCII (Fuji's original).
- 4 **Digital input** ... SV (set value) is selectable and various events are executable by external switches, etc.
- 5 **Heating and cooling control** ... Applicable to even a self-heating process.
- 6 **Heater burnout alarm** ... Equipment damage can be prevented.
- 7 **Various alarm function** ... Delay action, excitation/non-excitation selection or latch function can be combined with alarm.
- 8 **Remote SV input** ... SV (set value) can be selected with 1 to 5V DC signals from outside.

1 Re-transmission output in 4 to 20 mA DC

A cost corresponding to one temperature sensor can be reduced just by connecting a PV transfer signal to a recorder.

- Output signal: 4 to 20 mA DC
- Kinds of output: Any one of process value (PV), set value (SV), control output (MV) and PV-SV (DV)

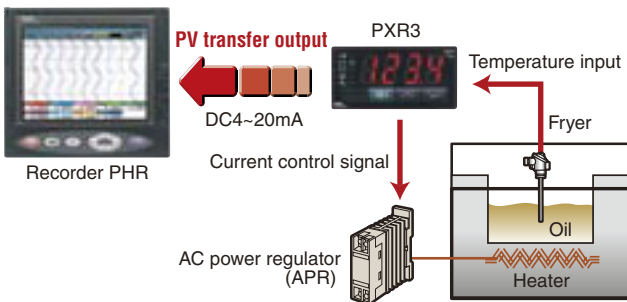

3 RS-485 communication

Via the RS-485 interface, PXR is connectable with a computer, programmable operation display and PLC.

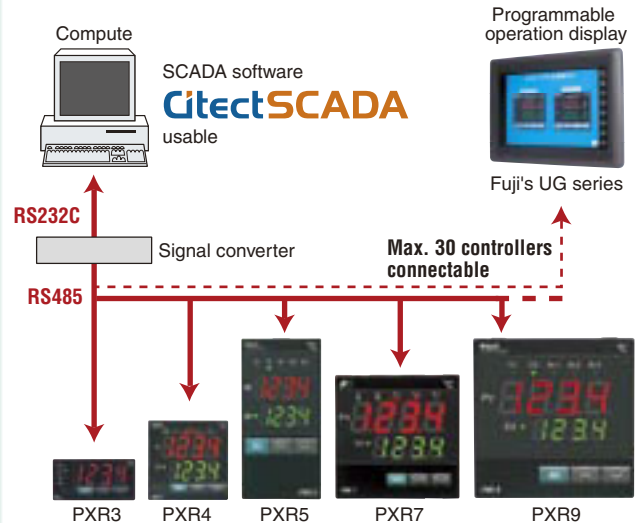

2 8-step ramp/soak function

Temperature gradient control of furnace >>> For control in a heat pattern

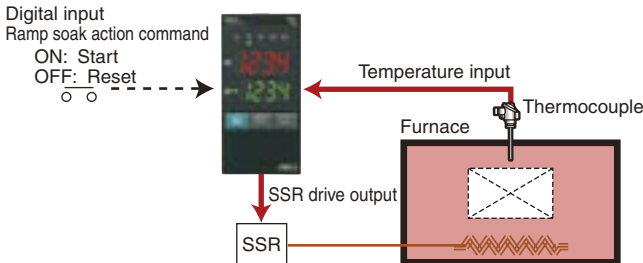

[Ramp soak function]
Temperature rise/fall pattern is controlled by setting a heat pattern having a gradient. Action start/resetting can be commanded externally.

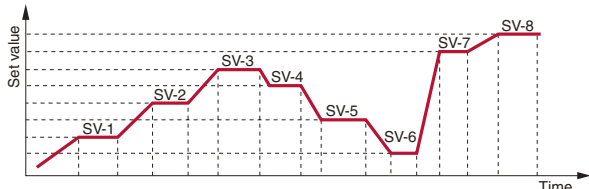

4 Digital input

Temperature control of oven >>> For changing set value readily

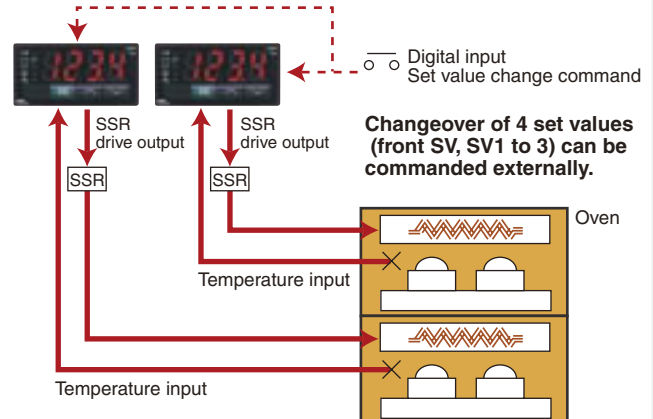

Changeover of 4 set values (front SV, SV1 to 3) can be commanded externally.

5 Heating and cooling control

For control of both heating and cooling with a single controller
Heating and cooling outputs can be overlapped with each other or a dead band can be provided.

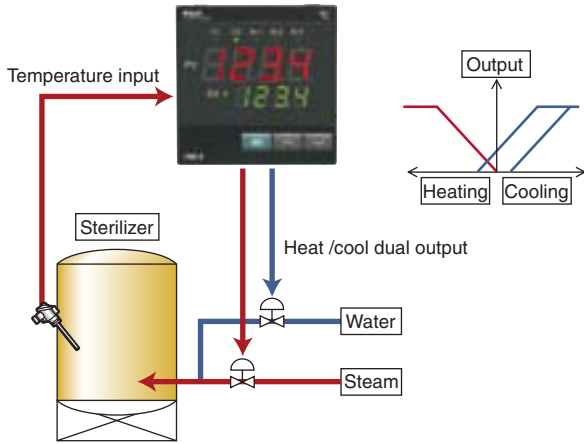

[Energy saving in cattle shed]

- Both heating and cooling are controlled with only one temperature controller utilizing its 2 control outputs.
- Power consumption can be curbed by controlling a cooling fan motor with inverter.

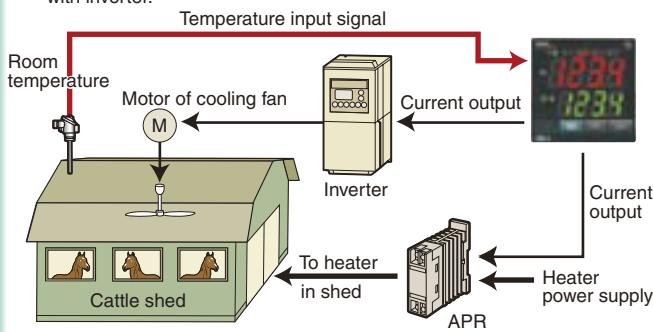

6 Heater burnout alarm

Alarm output will be issued when heater burnout is detected.

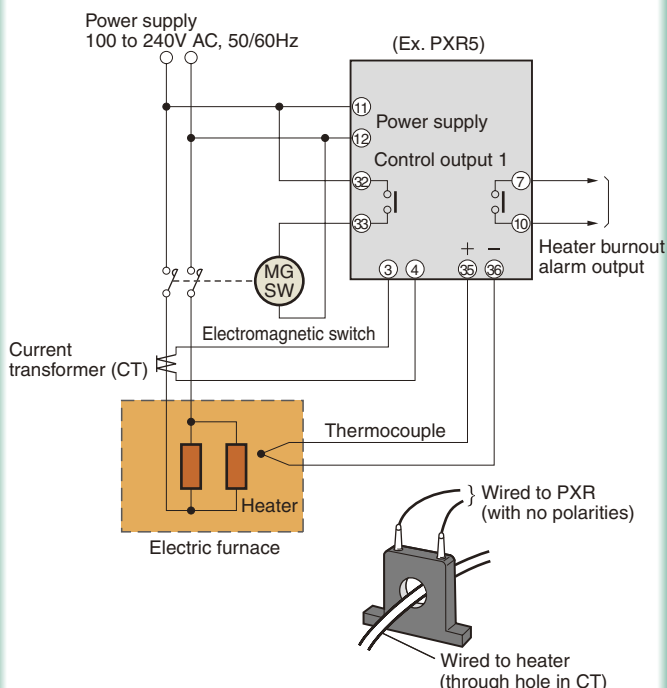

7 Various alarm function

Max. 3 points are settable.

	Kind of alarm	Action diagram
Absolute value alarms	Upper-limit absolute alarm	
	Lower-limit absolute alarm	
	Upper-limit absolute alarm (with hold)	
	Lower-limit absolute alarm (with hold)	
Deviation value alarms	Upper-limit deviation alarm	
	Lower-limit deviation alarm	
	Upper and Lower limits deviation alarm	
	Upper-limit deviation alarm (with hold)	
	Lower-limit deviation alarm (with hold)	
	Upper and Lower limits deviation alarm (with hold)	
Range alarms	Range upper and lower limits deviation (ALM1/2 independent operation)	
	Range upper and lower limits absolute value	
	Range upper and lower limits deviation	
	Range upper limit absolute value and lower limit deviation	
	Range upper limit deviation and lower limit absolute value	

8 Precise temperature control achieved by remote SV input from outside

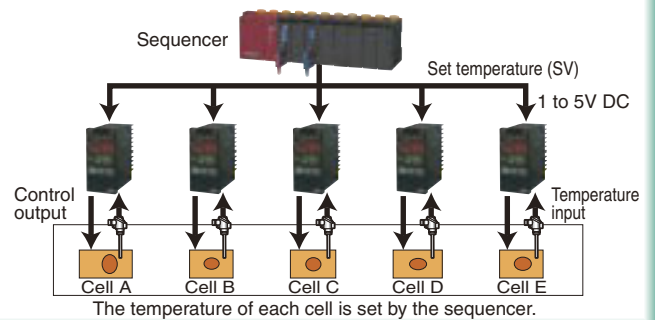



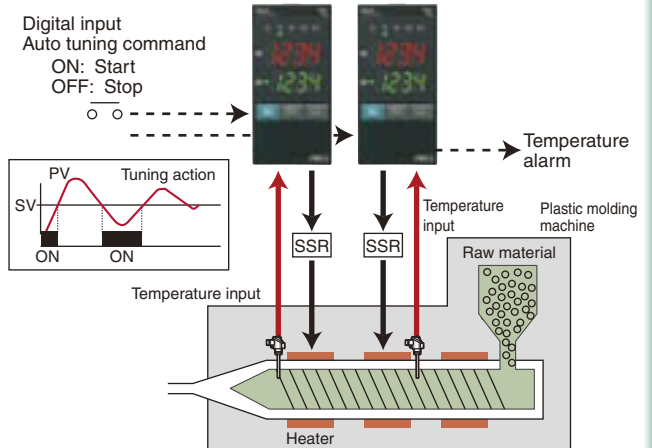

9 Temperature control of plastic molding machine

For stable temperature. Fuzzy + PID control applicable

Start/stop of auto tuning can be commanded externally.



[2] Products range

Type		PXR3	PXR4	PXR7	PXR5	PXR9
						
External dimensions	Front size	24×48mm	48×48mm	72×72mm	48×96mm	96×96mm
	Panel depth (with watertight packing)	97mm	78.8mm	79.7mm	78mm	79.5mm
Control method	ON/OFF	●	●	●	●	●
	PID with auto tuning	●	●	●	●	●
	Fuzzy PID with auto tuning	●	●	●	●	●
	PID with self-tuning	●	●	●	●	●
	Heating and cooling (PID,fuzzy PID)	●	●	●	●	●
Input signal	Resistance bulb Pt100	●	●	●	●	●
	Thermocouple J,K,R,B,S,T,E,N,PL II	●	●	●	●	●
	Voltage/current DC1~5V, DC4~20mA	●	●	●	●	●
Output signal	Control output1 (heating)	Relay contact	●	●	●	●
		SSR/SSC drive	●	●	●	●
		DC4~20mA	●	●	●	●
	Control output 2 (cooling)	Relay contact	●	●	●	●
		SSR/SSC drive	●	●	●	●
		DC4~20mA	●	●	●	●
Manual operation (Note1)		—	●	●	●	●
Alarm output (option)		● (Max. 2 points)	● (Max. 3 points)	● (Max. 3 points)	● (Max. 3 points)	● (Max. 3 points)
Heater burnout alarm (option)		—	●	●	●	●
8-step ramp soak (option)		●	●	●	●	●
RS-485 communication (option)		●	●	●	●	●
Digital input (option)		● (Max. 2 points)	● (Max. 2 points)	● (Max. 2 points)	● (Max. 2 points)	● (Max. 2 points)
Re-transmission (4 to 20mA DC)		●	●	●	●	●
Remote-Setpoint		—	●	●	●	●
Power supply voltage	AC100~240V 50/60Hz	●	●	●	●	●
	DC24V, AC24V 50/60Hz	●	●	●	●	●
Front waterproof structure		●	●	●	●	●
External terminal structure		Plug-in terminal	M3 screw terminal	M3 screw terminal	M3 screw terminal	M3 screw terminal
DIN rail mounting		●	—	—	—	—
Terminal cover		—	●	●	●	●
Applicable standards	UL, C-UL	●	●	●	●	●
	CSA	●	●	—	●	●
	CE mark	●	●	●	●	●

Others

DIN rail mounting type (48×48mm)



See PXW4, PXZ4 and PXV4 on page 22.

72×72mm size



See PXW7, PXZ7 on page 22.

[4] Specifications

■ General specifications

Power supply voltage	100 V (-15%) to 240 V (+10%) AC, 50/60 Hz or 24 V (±10%) AC 50/60 Hz, 24 V (±10%) DC
Power consumption	When using 100 V AC: 6 VA (PXR3), 8 VA (PXR4,7), 10 VA (PXR5,9) When using 220 V AC: 8 VA (PXR3), 10 VA (PXR4,7), 12 VA (PXR5,9) When using 24 V AC/DC: 8 VA (PXR3), 10VA (PXR4,7), 12VA (PXR5,9)
Insulation resistance	20 MΩ or more (500 V DC)
Dielectric strength	Power supply-ground ... 1500 V AC for 1 min Power supply-others ... 1500 V AC for 1 min Ground-relay output ... 1500 V AC for 1 min Ground-alarm output ... 1500 V AC for 1 min Others ... 500 V AC for 1 min
Input impedance	Thermocouple: 1 MΩ or more Voltage: 450Ω k or more Current: 250Ω (external resistor)
Allowable signal source resistance	Thermocouple: 100Ω or less Voltage: 1kΩ or less
Allowable wiring resistance	Resistance bulb: 10Ω or less per wire
Reference junction compensation accuracy	±1°C (at 23°C)
Input value correction	±10% of measuring range
Set value correction	±50% of measuring range
Input filter	0 to 900.0 sec settable in 0.5 sec steps (first order lag filter)
Noise reduction ratio	Normal mode noise (50/60 Hz): 50 dB or more Common mode noise (50/60 Hz): 140 dB or more
Applicable standards	UL (UL873) CSA (C22.2 No.24-93) ... Not available on 72x72mm size CE mark (LVD : EN61010-1, EMC : EN61326-1)

■ Control function of standard type

Control action	PID control (with auto tuning, self-tuning) Fuzzy control (with auto tuning)
Proportional band (P)	0 to 999.9% of measuring range settable in 0.1% steps
Integral time (I)	0 to 3200 sec settable in 1 sec steps
Differential time (D)	0 to 999.9 sec settable in 0.1 sec steps On/off action if P = 0. Proportional action when I, D = 0.
Proportional cycle	1 to 150 sec settable in 1 sec steps Only for relay contact output or SSR/SSC drive output
Hysteresis width	0 to 50% of measuring range For On/off action only
Anti-reset windup	0 to 100% of measuring range Automatically validated at auto tuning
Input sampling cycle	0.5 sec
Control cycle	0.5 sec

■ Input section

Input signal	Thermocouple : J, K, R, B, S, T, E, N, PL II Resistance bulb : Pt100 Voltage, current: 1 to 5 V DC, 4 to 20 mA DC (Apply current input after connecting the furnished 250Ω resistor to input terminal.)
Measuring range	See measuring range table
Burnout	For thermocouple or resistance bulb input Control output upper/lower are selectable

■ Output section of standard type (control output 1)

Control output 1	Select one as follows Relay contact: SPDT contact: 220V AC/30V DC, 3A (resistive load) For PXR3, SPST contact Mechanical life 10 million operations (no load) Electrical life 100,000 operations (rated load) Minimum switching current 100mA (24V DC) For PXR3, 10 mA (5 V DC) SSR / SSC drive (Voltage pulse): ON: 17 to 25 V DC, For PXR3, 12 to 16 V DC OFF: 0.5V DC or less Max. current: 20mA or less 4 to 20mA DC: Allowable load resistance 600Ω or less For PXR3, 100 to 500Ω
-------------------------	---

■ Control functions of heating/cooling control type (option)

Control action	PID control (with auto tuning)
Heating side proportional band (P)	0 to 999.9 % of measuring range
Cooling side proportional band (P)	Heating side "P" × cooling side coefficient (Automatically set in auto tuning) Cooling side proportional band coefficient: 0 to 100.0 On/off action if P=0
Integral time (I)	0 to 3200 sec (common to heating and cooling sides)
Differential time (D)	0 to 999.9 sec (common to heating and cooling sides) P,I,D=0:ON/OFF action (without dead band) for heating and cooling I,D=0:Proportional action
Proportional cycle	1 to 150 sec For relay contact output or SSR/SSC drive output only
Hysteresis width	0.5% of measuring range common to heating and cooling sides, For On/off action only
Anti-reset windup	0 to 100% of measuring range Automatically validated at auto tuning
Overlap, dead band	±50% of heating side proportional band
Input sampling cycle	0.5 sec
Control cycle	0.5 sec
Manual operation	Manual operation -3 to 103% (except for PXR3)

■ Output section of heating/cooling control type (control output 2) (option)

Control output 2	Select one as follows Relay contact: SPST contact: 220V AC/30V DC, 3A (resistive load) Mechanical life 10 million operations (no load) Electrical life 100,000 operations (rated load) Minimum switching current 100mA (24V DC) For PXR3, 10 mA (5 V DC) SSR/SSC drive (Voltage pulse): ON: 17 to 25 V DC, For PXR3, 12 to 16 V DC OFF: 0.5V DC or less Max. current: 20mA or less 4 to 20mA DC: Allowable load resistance 600Ω or less For PXR3, 100 to 500Ω
-------------------------	---

■ Operation and display section

Parameter setting method	Digital setting by 3 keys With key lock function
Display	Process value/set value Selective display (PXR3 : Single display) 4 digits, 7-segment LED
Status display LED	Control output, process alarm output, Heater burnout alarm output (unavailable for PXR3)
Setting accuracy	0.1% or less of measuring range
Indication accuracy (at 23°C)	Thermocouple: (0.5% of measuring range) 1 digit 1°C For thermocouple R at 0 to 500°C ... (1% of measuring range) 1 digit 1°C For thermocouple B at 0 to 400°C ... (5% of measuring range) 1 digit 1°C Resistance bulb, voltage/current: (0.5% of measuring range) 1 digit

■ Alarm (option)

Alarm kind	Absolute alarm, deviation alarm, zone alarm with upper and lower limits for each Hold function available (see page 15) Alarm latch, Excitation/non-excitation selecting function provided
Alarm ON-delay	Delay setting 0 to 9999 sec settable in 1 sec steps
Process alarm output	Relay contact: SPST contact: 220 V AC/30 V DC, 1 A (resistive load) Mechanical life 10 million operations (no load) Electrical life 100,000 operations (rated load) Minimum switching current 100 mA (5 V DC) For PXR3, 10 mA (5 V DC). MAX 2 points (PXR3), MAX 3 points (PXR4, 5, 7, 9) output cycle 0.5 sec

[4] Specifications

■ Heater burnout alarm (option, unavailable for PXR3)

Heater current detection (option), unavailable for PXR3	Current detector: CTL-6-S-H for 1 to 30 A / CTL-12-S36-8 for 20 to 50 A Current detection accuracy: 10% of measuring range Alarm settable range: 1 to 50 A Available only when control output is relay contact or SSR/SSC drive. However, detection is possible when control output ON lasts 500 ms or longer.
Heater burnout alarm output unavailable for PXR3	Relay contact: SPST contact: 220 V AC/30 V DC, 1 A (resistive load) Mechanical life 10 million operations (no load) Electrical life 100,000 operations (rated load) Minimum switching current 100 mA (24 V DC) 1 output, output updating cycle 0.5 sec

■ Digital input (option)

Points	1 or 2
Electrical specifications	5 V DC, approx. 2 mA (OFF judgment for 3 V DC or more, ON judgment for 2 V DC or less)
Input pulse width	Min. 0.5 sec
Function (any one settable)	Set value (front SV, SV1 to 3) changeover Control action start/stop Ramp/soak action start / reset Auto tuning start / stop Alarm latch cancel and built-in timer start

■ Timer function (option)

Start	By digital input
Setting	0 to 9999 sec settable in 1 sec steps
Action	Event ON-delay or OFF-delay
Signal output	Alarm output relay used. Up to 3 points available.

■ Communication function (option)

Physical specifications	EIA RS485
Communication protocol	Modbus™ RTU mode or PXR protocol (Z-ASC II)
Communication method	2 wire method. Half duplex bit serial, start-stop sync type.
Data type	8 bits. Parity: odd/even/none.
Communication rate	9600bps
Connection aspect	multi-drop/up to 32 controllers connectable including master station
Communication distance	Total extension 500 m or less.
RS232C / RS485 signal converter (recommendation)	Isolated type Manufacturer: RA Systems Corp. (Japan) Model: RC-77 http://www.ras.co.jp Manufacturer: OMRON Co., Ltd (Japan) Model: KS3C-10 http://www.omron.co.jp

■ Re-transmission output function (option)

Output signal	DC 4-20mA
Load resistance	500Ω or less (PXR3), 600Ω or less (PXR4, 5, 7, 9)
Output updating	500ms
Output accuracy	0.3% FS (at 23°C)
Resolution	2000 or more
Kind of output signal	Any one among PV, SV, DV and MV (selectable by parameter)

■ Remote setpoint (option, not available on 24x48mm size)

Input signal	1 to 5 V DC, 1 point
Accuracy	±0.5% 1 digit (at 23°C)
Input sampling cycle	0.5 sec
Input scaling	Allowed
Display of remote mode	LED on Front panel
Input impedance	1MΩ or more

■ Other functions

Parameter mask function	Parameter display is disabled by software.
Ramp/soak function (option)	2 program pattern of 4 steps each, or 1 program pattern × 8 steps Digital input allows to start/reset the action.

■ Power failure processing

Memory protection	Held by non-volatile memory
--------------------------	-----------------------------

■ Self-check

Method	Program error supervision by watchdog timer
---------------	---

■ Operation and storage conditions

Ambient operating temperature	-10°C to 50°C
Ambient operating humidity	Less than 90% RH (no condensation)
Storage temperature	-20°C to 60°C

■ Optional items

Current detector (CT) (unavailable for PXR3)	For 1 to 30 A: CTL-6-S-H For 20 to 50 A: CTL-12-S36-8 (see page 17)
DIN rail mounting adapter (for PXR3)	ZZP*CTK368715P1 (for outline diagram, see page 11)
Terminal cover	PXR4 : ZZPPXR1-A230 PXR5/9 : ZZPPXR1-B230 (for outline diagram, see page 11)
Instruction manual	For communication function (see list of related documents on page 10)

■ Structure

Mounting method	Panel flush mounting PXR3 can be mounted to rail/wall by using the DIN rail mounting adapter available at option.
External terminal	Plug-in terminal (PXR3) or M3 screw terminal (PXR4, 5, 7, 9)
Case material	Plastic (non-combustible grade UL94V-0 equivalent)
Dimensions	See the outline diagram on page 11.
Weight	Approx. 150 g (PXR3), 200 g (PXR4), 250g (PXR7) 300 g (PXR5), 300 g (PXR9)
Protective structure	Front waterproof structure: NEMA4X (IEC standard IP66 equivalent)(when mounted on panel with our genuine packing. Waterproof feature unavailable in close mounting of multiple units) Rear case: EC IP20
Outer casing	Black (front frame, case)

■ Scope of delivery

Scope of delivery	Controller, panel mounting bracket, front watertight packing, instruction manual, 250 resistor (for current input)
--------------------------	--

■ Measuring range table

	input signal	measuring range(°C)	measuring range(°F)
resistance bulb	Pt100	-199 to 850	-326 to 1562
	Thermocouple		
	J	0 to 800	32 to 1472
	K	0 to 1200	32 to 2192
	R	0 to 1600	32 to 2912
	B	0 to 1800	32 to 3272
	S	0 to 1600	32 to 2912
	T	-150 to 400	-238 to 752
	E	-150 to 800	-238 to 1472
	N	0 to 1300	32 to 2372
	PL II	0 to 1300	32 to 2372
DC voltage	1 to 5V	scaling range	-1999 to 9999
DC current	4 to 20mA		

Note 1: For current input connect the supplied 250Ω resistor at the input terminal.

Note 2: When the measuring range exceeds 1000°C (1832°F), decimal point cannot be used.

[4] Specifications

■ Insulation block diagram

Power supply section	Measurement input Heater current detector input Remote SV input Internal circuit ----- Voltage pulse, 4 to 20mA DC control output 1 Voltage pulse, 4 to 20mA DC control output 2 Transfer output ----- Digital input (In case of Re-Transmission by PXR3)
Relay contact control output 1	
Relay contact control output 2	
Alarm relay output 1	
Alarm relay output 2	
Alarm relay output 3 or heater break alarm output (PXR3 not included)	Communication (RS-485) Digital input (In case of Re-Transmission by PXR3, 4, 5, 7, 9)

Note: Basic insulation (dielectric strength 1500 V AC) between blocks delimited by line — .
 Functional insulation (dielectric strength 500 V AC) between blocks delimited by line - - - - .
 Non isolated between blocks which are not delimited from each other.

■ Caution in use Control output

Model	Voltage puls (for SSR drive)		DC 4 to 20 mA Allowable load resistance
	Voltage	Max. Current	
PXR3	15V DC	20mA	100 to 500Ω
PXR4, 5, 7, 9	24V DC	20mA	600Ω or less
PXV3	5.5V DC	20mA	600Ω or less
PXV	24V DC	60mA	600Ω or less
PXW	24V DC	60mA	600Ω or less
PXZ	24V DC	60mA	600Ω or less

Differences from other models are listed at left. For replacement, check is required to see if the specifications of control end are satisfied.

■ List of related documents

	PXR3	PXR4, 7	PXR5	PXR9
Instruction manual	TN1PXR3-E	TN1PXR-E	TN1PXR5/9-E	
Operation manual	ECNO:409	ECNO:406		
Communication function manual	MODBUS	TN512642-E		
	Z-ASCI	TN512644-E		

*The above documents can be downloaded from our Internet home page. <http://www.fic-net.jp/eng>

Mounting to DIN rail (PXR3 only)

Mountable to a DIN rail using the DIN rail mounting adapter available at option. With this adapter, also mountable to a wall.

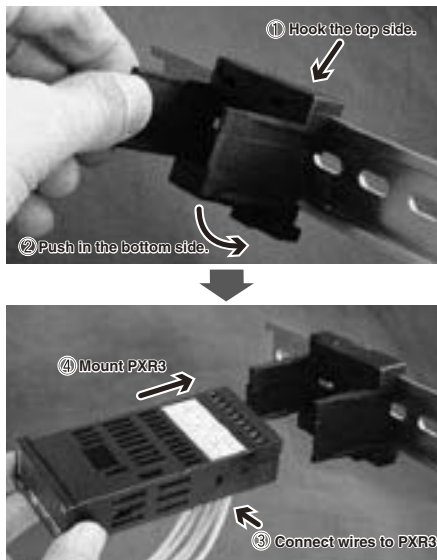

Terminal cover (PXR4)

The terminal block can be protected by the terminal cover available at option.

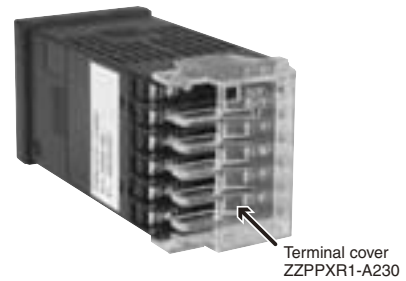

With PXR3 DIN rail mounting adapter (available at option)

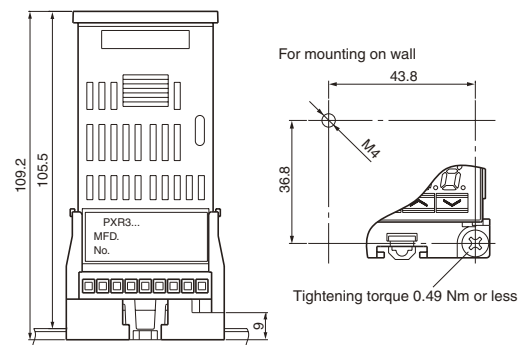
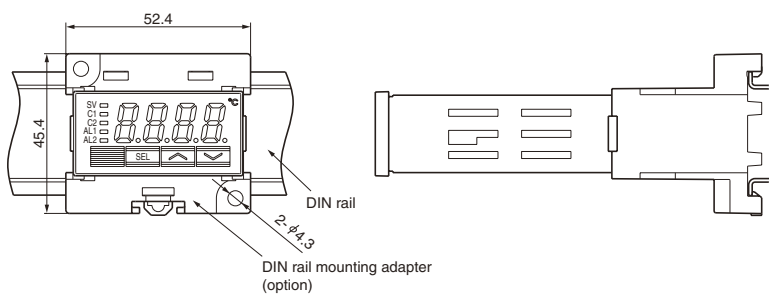

Caution on drilling in panel: In case of coating, etc. after drilling, the above dimensions must be followed in the finished status.

[5] Outline and Panel Cutout Dimensions

(unit: mm)

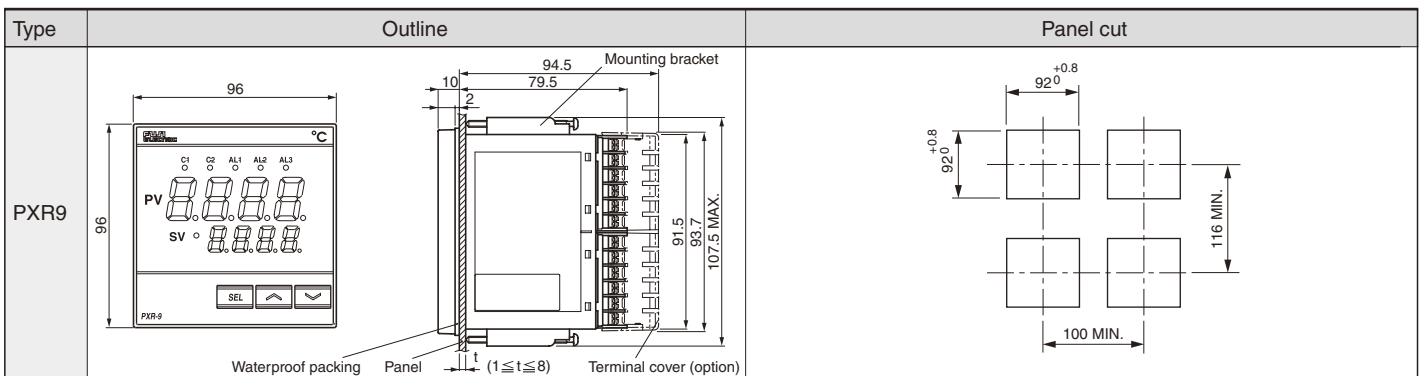
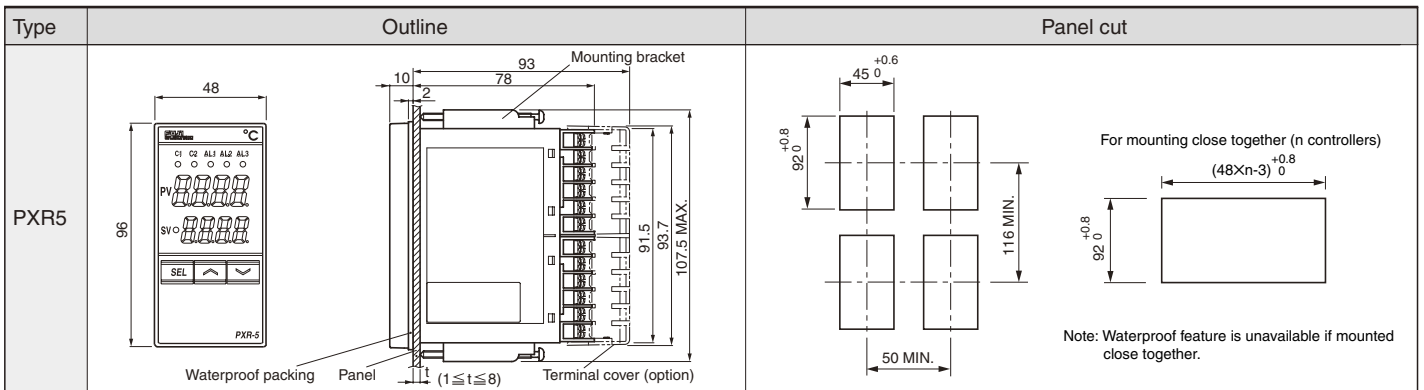
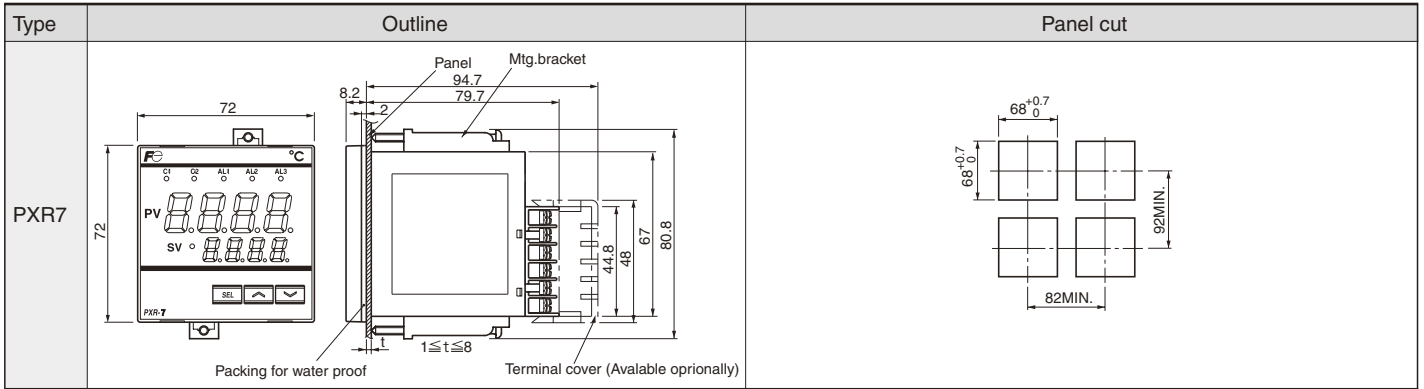
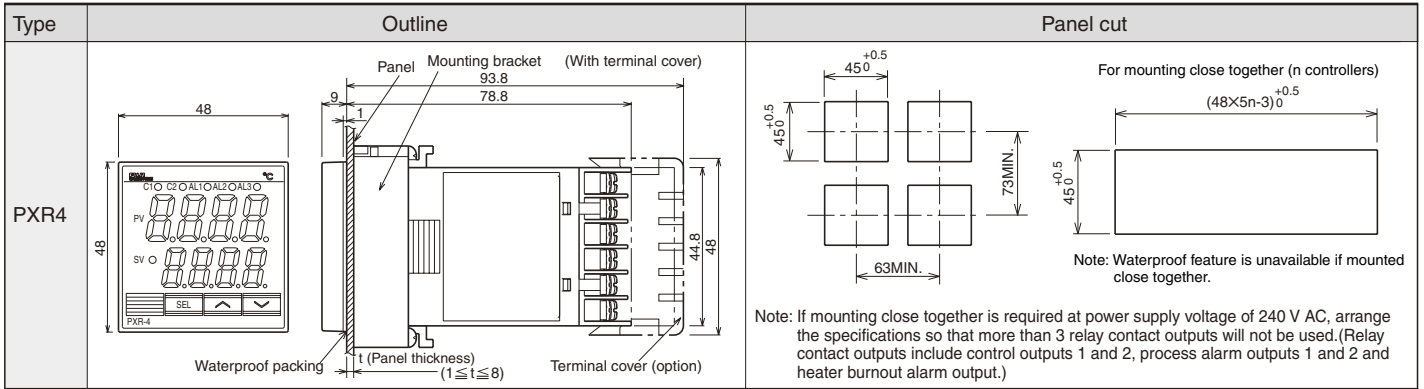
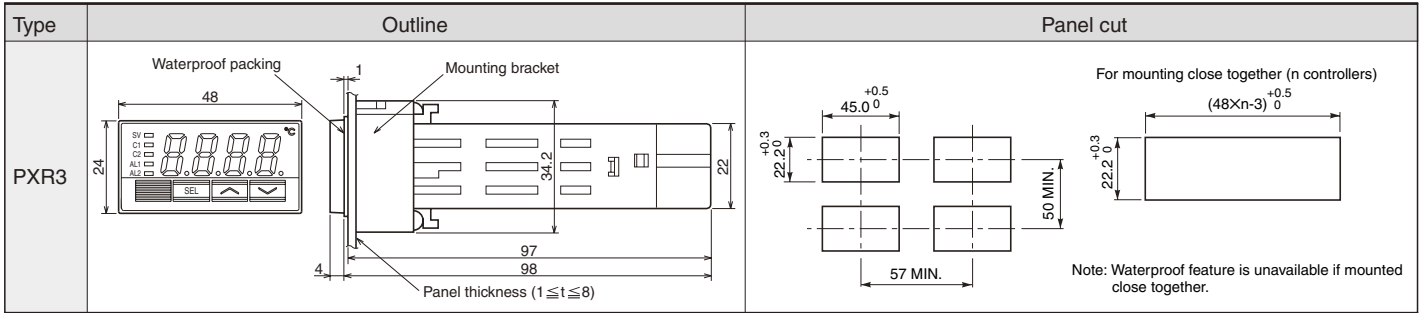

[6] External connection diagram

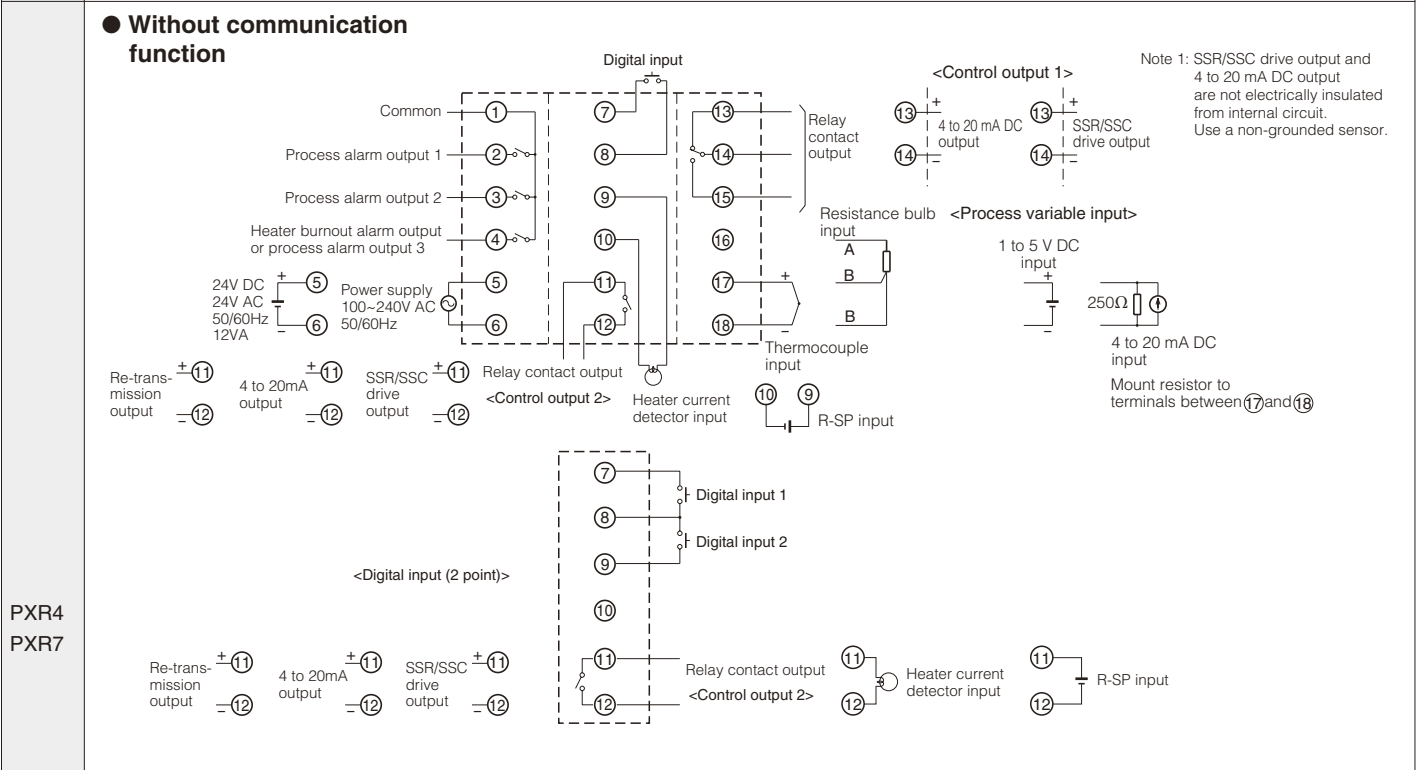
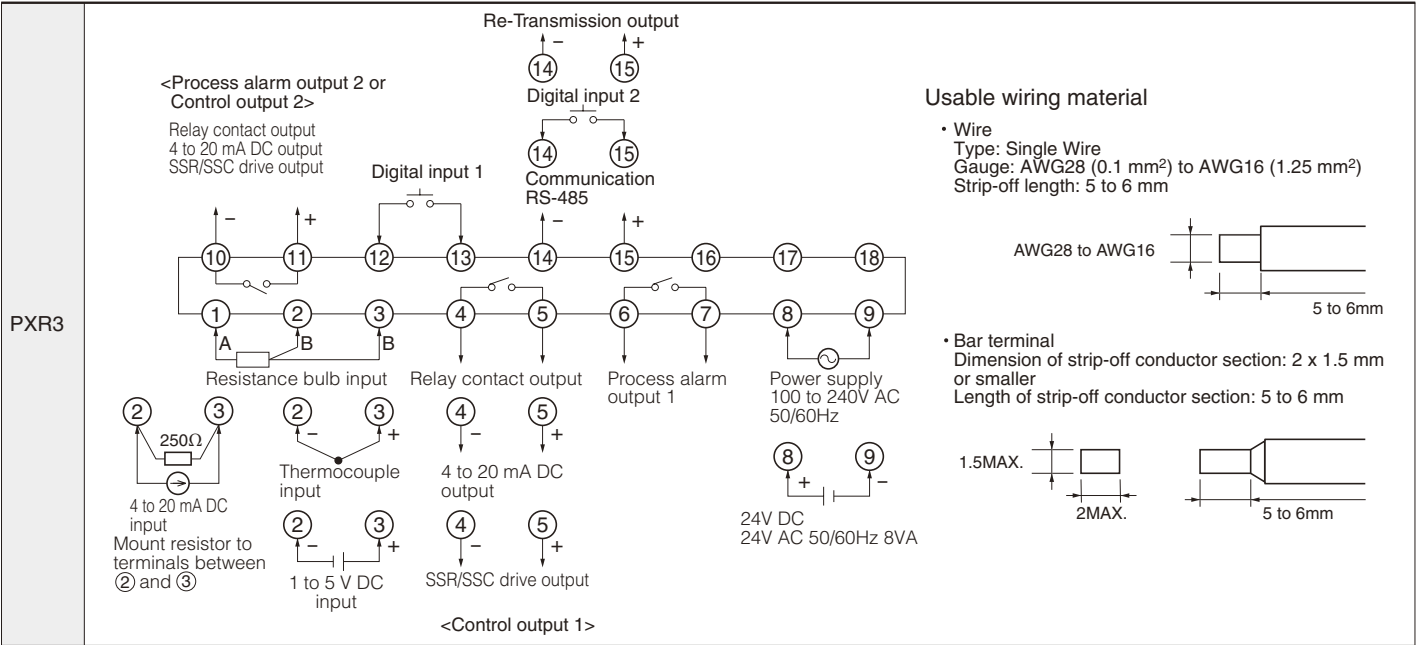

< use M3 screw >



[6] External connection diagram

● Without communication function

< Non digital input or with digital input (1 point) >

<Control output 2>

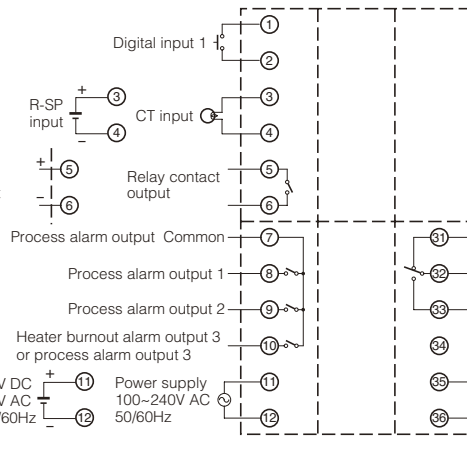
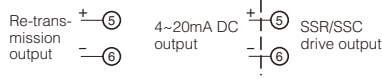

Note 1: Mount supplied resistor to terminals between 35 and 36

<Control output 1>

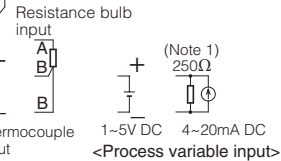
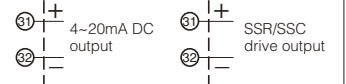

● Without communication function

< With digital input (2 point) >

<Control output 2>

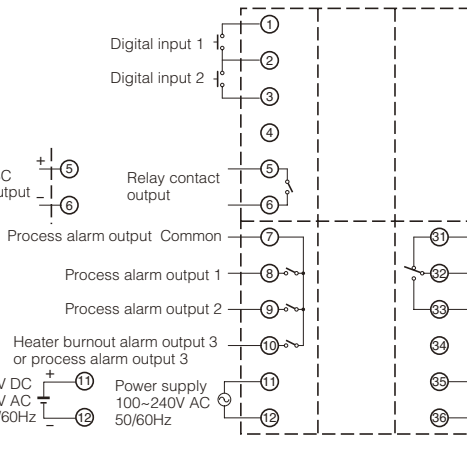

Note 1: Mount supplied resistor to terminals between 35 and 36

<Control output 1>

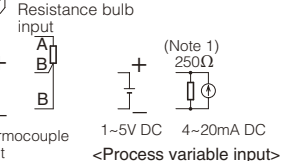
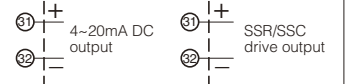

PXR5
PXR9

● With communication function

<Control output 2>

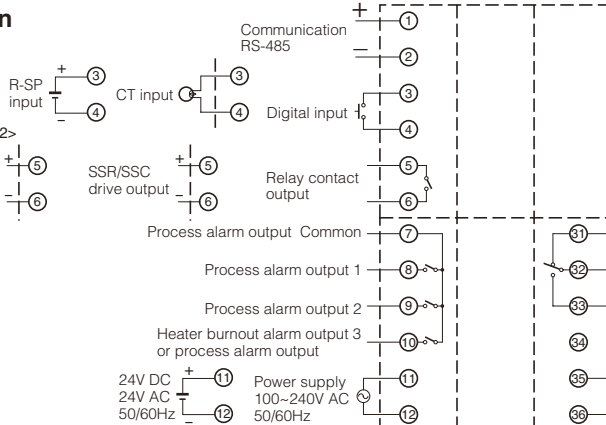
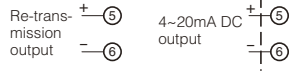

Note 1: Mount supplied resistor to terminals between 35 and 36

<Control output 1>

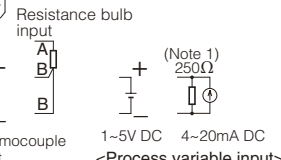
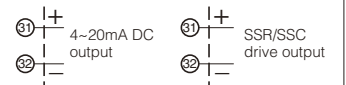

< use M3 screw >

PXR3



PXR4

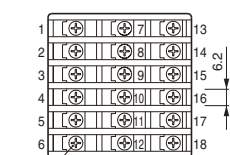

M3 screw terminal

PXR7

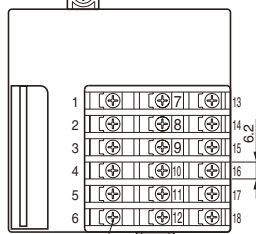

M3 screw terminal

PXR5

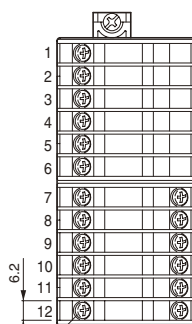

M3 screw terminal

PXR9

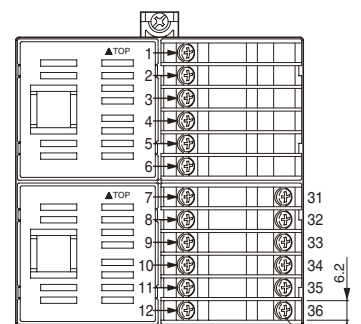

M3 screw terminal

[7] Functions

Function0 Manual Operation

This function is selectable operation mode either "Auto" or "Manual" operation by change the parameter.
 MV output value is changeable by manual operation on Manual mode.

- Operation mode is stored while power down.
- Changeover method: Auto → Manual: Balanceless bump less
 Manual → Auto: Balance bump less
- MV setting value resolution: 1%(Settable by front key)
- MV setting range: -3~103%
- Auto-tuning and Self-tuning are not available while manual operation mode.

Function1 Control function

Fuzzy control function

Fuzzy operation is used to suppress overshoot so that the response to external disturbances is improved. By monitoring process value, overshoot is suppressed with the startup time remaining unchanged. At the same time, response to external disturbances is also improved.

- Comparison between fuzzy control and conventional control

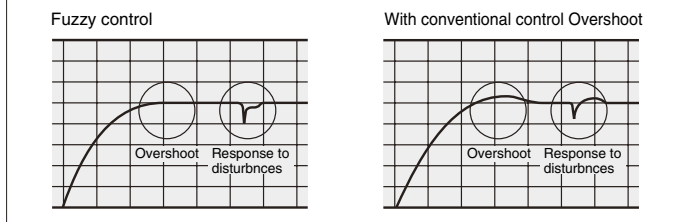

On/off action (2-position action)

When process value (PV) is below the set value (SV), output is turned on and the heater is energized as shown below. When PV is above SV, output is turned off and the heater is de-energized. In this way, output is turned on/off repeatedly with respect to the SV to keep the temperature constant. This method of control is called "on/off action (2-position action)."

- When "0" is assigned to parameter P, the on/off action will be selected.

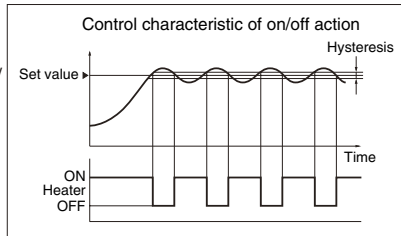

Point On/off action hysteresis setting

In on/off control, output turns on/off with respect to the set value. Therefore, output would change frequently in response to a slight change in the temperature. This might shorten the service life of the output relay and adversely affect the equipment connected with the temperature controller. To prevent this, a gap (hysteresis) is provided in the on/off action. This action gap is usually called "hysteresis."

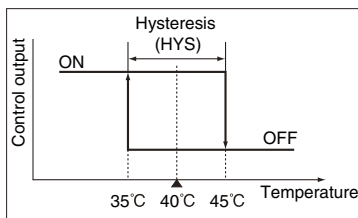

Example 1) Suppose that the temperature controller has a measuring range of 0 to 150°C and a hysteresis (HYS) of 10. When the set value is adjusted to 40°C, the heater turns off at 45°C and turns on at 35°C.

Example 2) For turning off the heater at 45°C in the figure at left, parameter [SVOF] should be set at "-5." Then, the heater turns off at 45°C and turns on at 35°C. (The above action is effective when the ONOFF parameter is set at OFF.)

Point Changeover of output action

Direct action or reverse action is settable by parameter [P-n1].

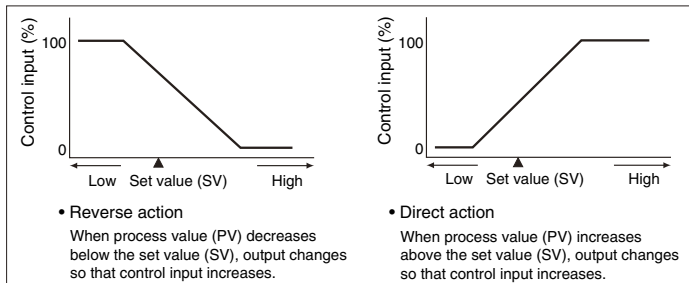

Heating / cooling control (option)

By a single controller both heating and cooling control output are obtained. (Both control outputs 1 and 2 are used.)

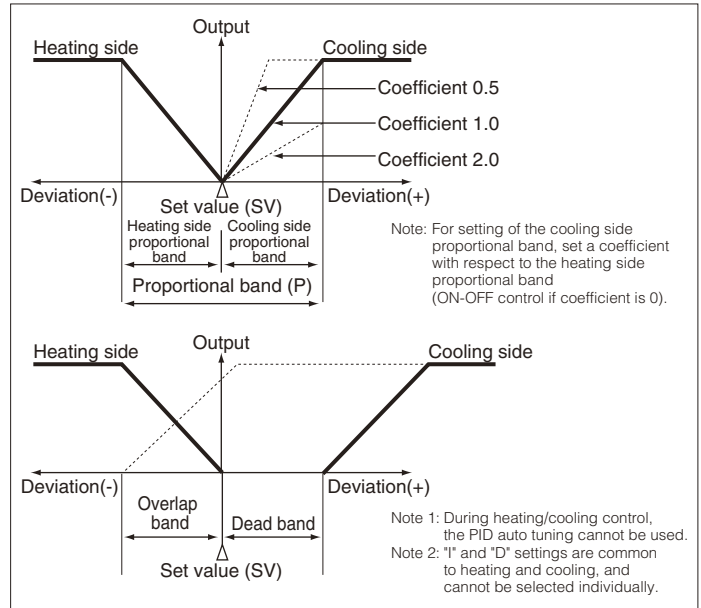

Function2 PID tuning function

Auto-tuning (AT)

PID parameters are automatically set by the controller's measurement and computation function. This instrument provides 2 types of auto-tuning functions; the standard type (auto-tuning with SV used as reference) and the low SV type (auto-tuning with the value 10% below SV used as reference).

(a) Standard type

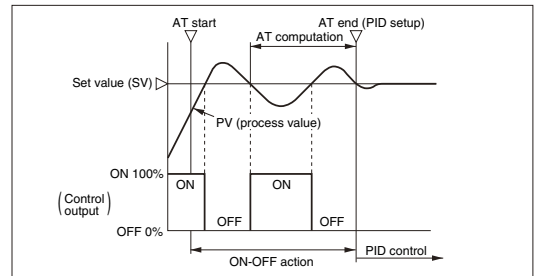

(b) Low PV type

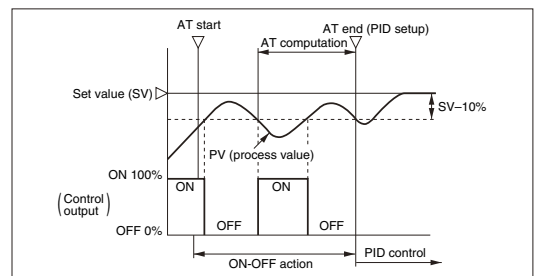

Self-tuning function

At power on, changing a set value or during external disturbance, tuning is made automatically so that the PID parameters are reoptimized.

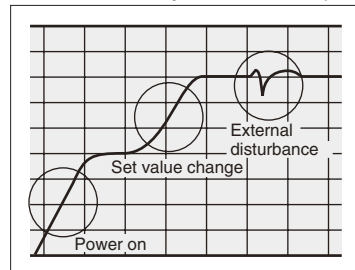

Note: For some objects to control, PID values could not be optimized.

Function3 Alarm (option)

• Kind of alarm and alarm type code

	ALM1	ALM2	ALM3	Alarm type	Operation figure
	0	0	0	No alarm	
Absolute value alarm	1	1	1	Upper-limit absolute value	
	2	2	2	Lower-limit absolute value	
	3	3	3	Upper-limit absolute value (with hold)	
	4	4	4	Lower-limit absolute value (with hold)	
Deviation value alarm	5	5	5	Upper-limit deviation	
	6	6	6	Lower-limit deviation	
	7	7	7	Upper and lower limits deviation	
	8	8	8	Upper-limit deviation (with hold)	
	9	9	9	Lower-limit deviation (with hold)	
	10	10	10	Upper and lower limits deviation (with hold)	
Range alarm	11	11	11	Range upper and lower limits deviation (ALM1/2 independent operation)	
	-	12	-	Range upper and lower limits absolute value	
	-	13	-	Range upper and lower limits deviation	
	-	14	-	Range upper limit absolute value and lower limit deviation	
	-	15	-	Range upper limit deviation and lower limit absolute value	

• Timer code

	ALM1	ALM2	ALM3	Alarm type	Operation figure
Timer	32	32	32	ON-delay timer	
	33	33	33	OFF-delay timer	
	34	34	34	ON/OFF-delay timer	

If change the kinds of parameter, please power ON/OFF PXR.

Note: (1) Alarm output is ON in the alarm band marked with hatched area
 (2) What is alarm with hold?
 The alarm is not turned ON immediately even when the measured value is in the alarm band. It turns ON when it goes out the alarm band and enters again.

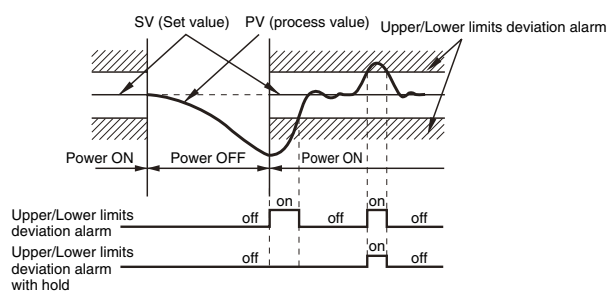

• Alarm code for setting value 2 points

	ALM1	ALM2	ALM3	Alarm type	Operation figure	
Upper and lower limits alarm	16	16	16	Upper and lower limits absolute value		
	17	17	17	Upper and lower limits deviation		
	18	18	18	Upper limit absolute value and lower limit deviation		
	19	19	19	Upper limit deviation and lower limit absolute value		
	20	20	20	Upper and lower limits absolute value (with hold)		
	21	21	21	Upper and lower limit deviation (with hold)		
	22	22	22	Upper limit absolute value and lower limit deviation (with hold)		
	23	23	23	Upper limit deviation and lower limit absolute value (with hold)		
	Range alarm	24	24	24	Range upper and lower limits absolute value	
		25	25	25	Range upper and lower limits deviation	
26		26	26	Range upper limit absolute value and lower limit deviation		
27		27	27	Range upper limit deviation and lower limit absolute value		
28		28	28	Range upper and lower limits absolute value (with hold)		
29		29	29	Range upper and lower limits deviation (with hold)		
30		30	30	Range upper limit absolute value and lower limit deviation (with hold)		
31		31	31	Range upper limit deviation and lower limit absolute value (with hold)		

Function4 Heater burnout alarm (option)

- Heater burnout is detected then the alarm is emitted immediately.
- Separate type current transformer(CT)specified by Fuji should be used.
- Alarm action point can be set by front panel keys.
- Detection is made only on a single-phase heater.
- This function cannot be used when controlling a heater with thyristor phase angle control system.

- Example of the connection of the heater burnout alarm (type PXR5, PXR9)

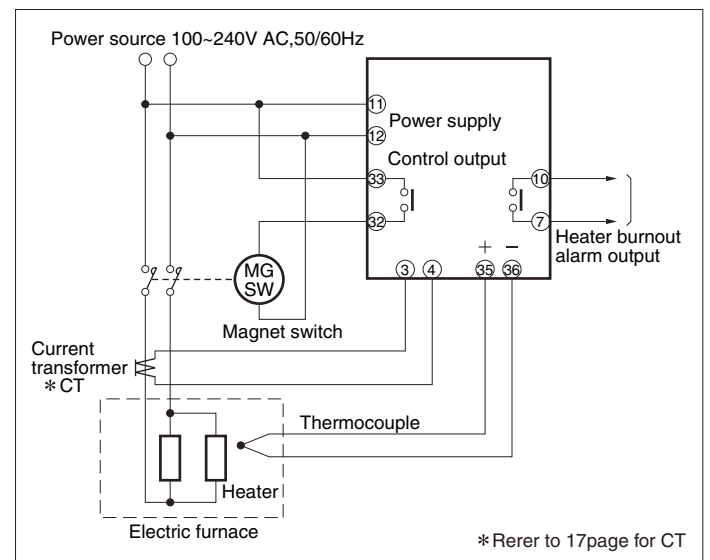

* Rerer to 17page for CT

[7] Functions

Function5 Parameter mask function

This instrument provides a function (parameter mask function) to mask (conceal) the display of individual parameters. To effect parameter mask(non-display)or non- mask (display),appropriate values should be set to DSP1-13.

Example of setting to (DSP1-13)

(a) To mask parameter P

- 1) Check DSP value for Preferring to parameter table
- 2) Add 2 to the value set to DSP3.

Parameter	DSP
P	DSP3-2
I	DSP3-4
D	DSP3-8

(b) To mask parametaer P,I,D

- 1) Check DSP value for P,I,D referring to parameter table.
- 2) Add 2+4+8=14 to the value set to DSP3.

For allocation of DSP of each parameter, refer to the parameter table on Page18. DSP1-13 cannot be masked.

Function6 Ramp soak function (option)

Function of automatically changing the set point value with the elapsing of time, in accordance with the preset pattern, as shown below.This function is capable of programming a 2 program pattern of 4 steps each, or 1 program pattern × 8 steps.

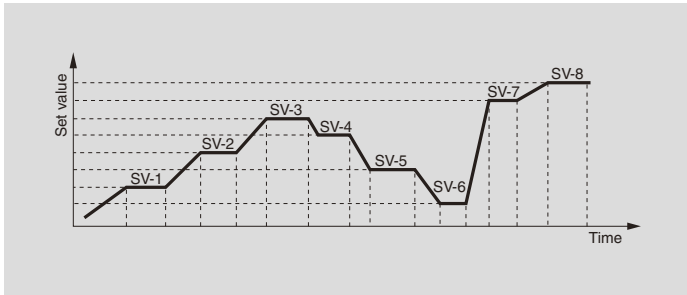

Function7 RS-485 Communication function (option)

With RS-485 (Modbus™ protocol) interface, a connection with computer, touch panel or PLC is allowed.

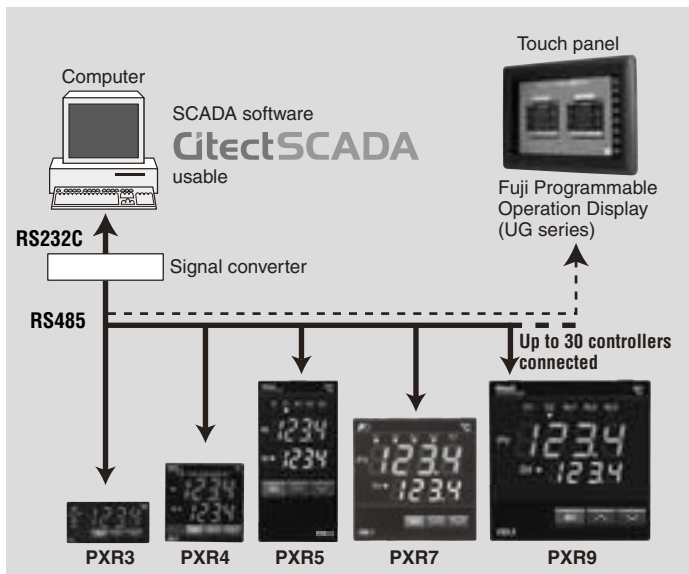

Either communication protocol below is selectable. Selection should be made according to system configuration.

- 1) Modbus™ RTU mode: An open protocol generally used in particular outside Japan. In case the host side supports this protocol, connection is allowed without a program.
- 2) Z-ASCII (Fuji's original) Because transmission code is ASCII, programming with PLC, etc. is simple.

Function8 Digital input (option)

External digital input allows one of the following functions.

- Change the set value (Front SV, SV1-3)
- Start/stop the control action
- Start/reset the ramp/soak
- Start/stop the auto tuning
- Cancel the alarm latch
- Start the incorporated timer

* The above functions can be combined when two digital inputs are used.

Function9 Timer function (option)

By Digital input, ON-delay or OFF delay timer can be started. That is, relay output is turned on/off after certain period of time preset in parameter dLY1/dLY2/dLY3. As for relay output, alarm output relays are used. Up to 3 timer outputs can be obtained.

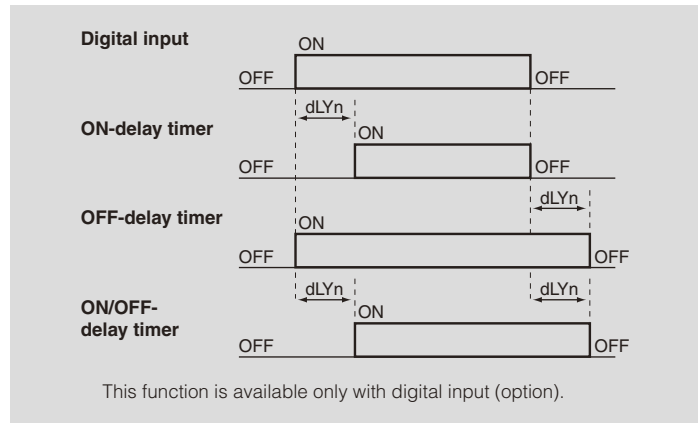

Function10 Analog Re-transmission (option)

- Output signal : 4 to 20 mA DC
- Kind of output : Any one of process value (PV), set value (SV), manipulated output value (MV) and process variable - set value (DV) (setting by front keys)

A cost corresponding to one temperature sensor can be reduced just by connecting a PV transfer signal to a recorder.

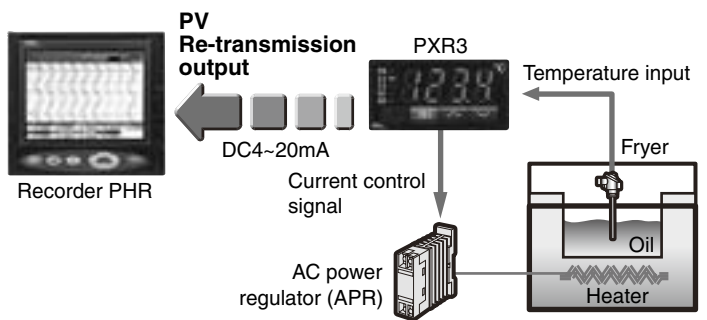

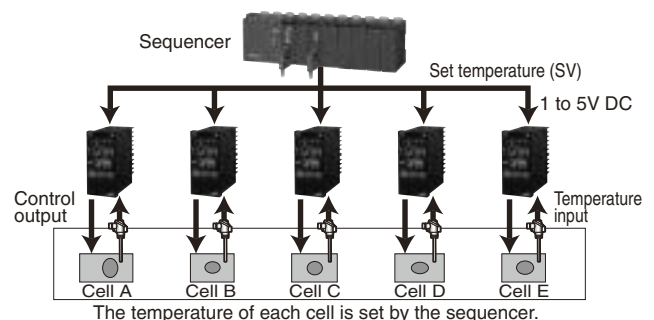

Function11 Remote SV input (option)

- SV (set value) can be selected with signals from outside.
- SV input signal: 1 to 5V DC

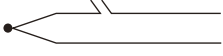

[8] Sensor fault operation

• Thermocouple

Condition	Display	Control output
Break 	UUUUU	ON or more than 20mA OFF or less than 4mA (Note)
Short circuit 	short-circuit point Temperature display	Input is controlled as short-circuit point temperature. (Note)

• Resistance bulb input

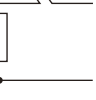
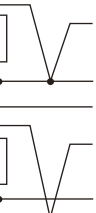
Condition	Display	Control output
Break 	UUUUU	ON or more than 20mA OFF or less than 4mA (Note)
	LLLLL	OFF or less than 4mA ON or more than 20mA (Note)
	LLLLL	ON or more than 20mA OFF or less than 4mA (Note)
2-wire or 3-wire break		
Short circuit 	LLLLL	OFF or less than 4mA ON or more than 20mA (Note)

• 1-5V DC

Break 	LLLLL	OFF or less than 4mA ON or more than 20mA (Note)
Short circuit 		

• 4-20mA DC

Over-range	UUUUU	OFF or less than 4mA (Note)
Under-range	LLLLL	ON or more than 20mA

(Note) Control output changes in operation according to the designation of burnout direction (parameter, "P-n1").
In case of Manual Mode, control output signal is MV output value.

Heater burnout alarm current detector (CT)

- Specification : For 20-50A
- Type : CTL-12-S36-8

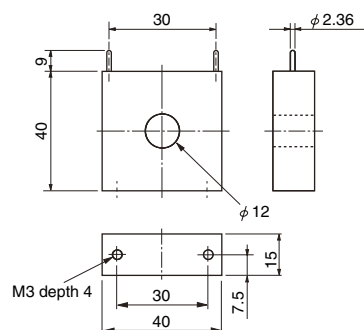

- Specification : For 1-30A
- Type : CTL-6-S-H
- "CTL-6-S" is printed on commodity as type.

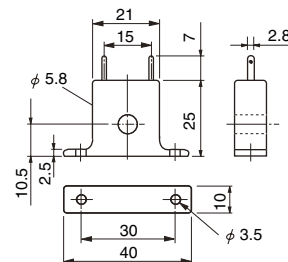

[9] Parameter table

Parameter table PXR (1/4)

Parameters for the PXR are classified under three blocks according to the frequency of use. The parameters of the second and third blocks are used at initialization or when they are of absolute necessity. Some parameters may not be displayed at the time of delivery depending on the type.

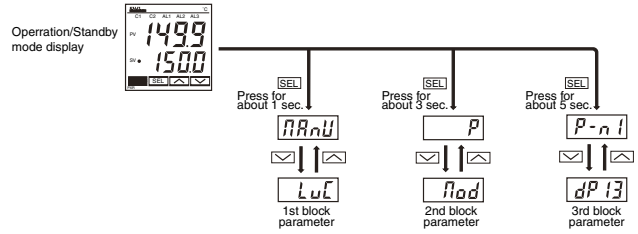

Parameters of the first block

Parameter display symbol	Parameter name	Description	Setting range	Value prior to delivery	User's set value	Parameter mask DSP						
MAnU	MAnU	Auto/Manual setting	Switches between Auto and Manual mode.	on : Manual mode oFF : Auto mode	OFF	dSP13-32						
STby	STby	Standby setting	Switches between RUN and Standby for control.	on: Control standby (Output: OFF, Alarm: OFF) oFF: Control RUN	OFF	dSP1-1						
CMod	CMod	Remote/Local setting	Switches between Remote and Local operations.	rEM : Remote LoCL : Local	LoCL	dSP13-8						
ProG	ProG	Ramp-soak control	Switches between Start, Stop, and Hold for ramp-soak control.	oFF: Stop rUn: Start HLd: Hold	OFF	dSP1-2						
LACH	LACH	Alarm latch cancel	Cancels the alarm latch.	0: Keeps the alarm latch. 1: Opens up the alarm latch.	0	dSP1-4						
AT	AT	Auto-tuning	Used for setting the constants for P, L, and d by auto-tuning.	0: OFF (Resets the auto-tuning or does not use it.) 1: ON (Performs the auto-tuning in the SV standard type.) 2: ON (Performs the auto-tuning in low PV type (SV value-10%FS).)	0	dSP1-8						
TM-1	TM-1	Timer 1 display	Displays the remaining time of timer 1.	- (Unit: seconds)	—	dSP1-16						
TM-2	TM-2	Timer 2 display	Displays the remaining time of timer 2.	- (Unit: seconds)	—	dSP1-32						
TM-3	TM-3	Timer 3 display	Displays the remaining time of timer 3.	- (Unit: seconds)	—	dSP1-64						
AL1	AL1	Set value of alarm 1	Sets the value at which alarm 1 is detected.	Type 1 to 3 Possible to set up within input range.	When the alarm type is absolute value: 0 to 100%FS When the alarm type is deviation: -100 to 100%FS	10	dSP1-128					
A1-L	A1-L	Lower limit value of alarm 1	Sets the lower limit value at which alarm 1 is detected.					0 to 15	10	dSP2-1		
A1-H	A1-H	Upper limit value of alarm 1	Sets the upper limit value at which alarm 1 is detected.								10	dSP2-2
AL2	AL2	Set value of alarm 2	Sets the value during which alarm 2 is detected.									
A2-L	A2-L	Lower limit value of alarm 2	Sets the lower limit value at which alarm 2 is detected.					10	dSP2-8			
A2-H	A2-H	Upper limit value of alarm 2	Sets the upper limit value at which alarm 2 is detected.							10	dSP2-16	
AL3	AL3	Set value of alarm 3	Sets the value at which alarm 3 is detected.									32 to 34
A3-L	A3-L	Lower limit value of alarm 3	Sets the lower limit value at which alarm 3 is detected.					10	dSP2-64			
A3-H	A3-H	Upper limit value of alarm 3	Sets the upper limit value at which alarm 3 is detected.							10	dSP2-128	
LoC	LoC	Key lock	Setting of key lock status.			0	dSP3-1					

○: Setting enable, ×: Setting disable

Parameter table PXR (2/4)



•Parameters of the second block

Parameter display symbol	Parameter name		Description	Setting range	Value prior to delivery	User's set value	Parameter mask DSP
<i>P</i>	P	Proportional band	Set <i>P</i> to 0.0 to select the ON/OFF control (Two-position control).	0.0 to 999.9%	5.0		dSP3-2
<i>I</i>	i	Integral time	Integration OFF at 0	0 to 3200 seconds	240		dSP3-4
<i>d</i>	d	Differential time	Differentiation OFF at 0	0.0 to 999.9 seconds	60.0		dSP3-8
<i>HYS</i>	HYS	Hysteresis range for ON/OFF control	Sets the hysteresis for ON/OFF control.	0 to 50%FS	1		dSP3-16
<i>Cool</i>	Cool	Cooling-side proportional band coefficient	Automatically set by auto-tuning function. Selecting 0 switches to cooling-side ON/OFF operation.	0.0 to 100.0	1.0		dSP3-32
<i>db</i>	db	Dead band	Shifts the cooling-side output value.	-50.0 to +50.0	0.0		dSP3-64
<i>bAL</i>	bAL	Manual reset value	Do not modify the default value set at the factory.	-100 to 100%	0.0/50.0		dSP3-128
<i>Ar</i>	Ar	Anti-reset windup	Automatically set by auto-tuning function.	0 to 100%FS	100		dSP4-1
<i>Ctrl</i>	Ctrl	Control algorithm	Selects the control algorithm.	Pid: Runs normal PID control. FUZY: Runs PID control with fuzzy logic. SELF: Runs PID control with self-running.	Pid		dSP4-2
<i>SLFb</i>	SLFb	PV (Measured value) stable range	Sets the PV stable range for the self-tuning operation.	0 to 100%FS	2%FS		dSP4-4
<i>onoF</i>	onoF	Setting HYS (Hysteresis) mode	Selects the hysteresis operation at ON/OFF control.	oFF: Starts the two-position control at the values of SV+HYS/2 and SV-HYS/2. on: Starts the two-position control at the values of SV and SV+HYS, or SV and SV-HYS.	ON		dSP4-8
<i>TC</i>	TC	Cycle time of control output 1	Not shown at 4-20mA DC output	RY, SSR: 1 to 150 seconds (Contact output = 30, SSR/SSC-drive output=2)	30/2		dSP4-16
<i>TC2</i>	TC2	Cycle time of control output 2 (cooling-side)	Not shown at 4-20mA DC output	1 to 150 seconds (Contact output = 30, SSR/SSC-drive output=2)	30/2		dSP4-32
<i>P-n2</i>	P-n2	Input signal code	Set this parameter when changing the types of temperature sensors.	1 to 16	Note 1		dSP4-64
<i>P-SL</i>	P-SL	Lower limit of measuring range		-1999 to 9999	Note 1		dSP4-128
<i>P-SU</i>	P-SU	Upper limit of measuring range		-1999 to 9999	Note 1		dSP5-1
<i>P-dP</i>	P-dP	Setting the decimal point position		0 to 2	Note 1		dSP5-2
<i>PVOF</i>	PVOF	PV (process value) offset	Shift the display of the PV.	-10 to 10%FS	0		dSP5-8
<i>SVOF</i>	SVOF	SV (Setting value) offset	Shift the SV. But the SV display is not changed.	-50 to 50%FS	0		dSP5-16
<i>P-dF</i>	P-dF	Time constant of input filter		0.0 to 900.0 seconds	5.0		dSP5-32
<i>ALN1</i>	ALM1	Alarm type 1	Sets the types of alarm operations.	0 to 34	0/5		dSP5-64
<i>ALN2</i>	ALM2	Alarm type 2	Sets the types of alarm operations.	0 to 34	0/9		dSP5-128
<i>ALN3</i>	ALM3	Alarm type 3	Sets the types of alarm operations.	0 to 34	0/0		dSP6-1
<i>STAT</i>	STAT	Status display of ramp-soak		-	OFF		dSP6-2
<i>PTn</i>	PTn	Selecting ramp-soak execute type	Selects ramp-soak patterns.	1: Performs 1st to 4th segments. 2: Performs 5th to 8th segments. 3: Performs 1st to 8th segments.	1		dSP6-4
<i>Sv-1</i>	Sv-1	1st target value/ Switching-SV value	Sets the 1st target SV of ramp-soak operation. / Selected at switching-SV function for DI1	Within the SV limit.	0%FS		dSP6-8
<i>TM1r</i>	TM1r	First ramp segment time	Sets the first ramp segment time.	0 to 99h59m	0.00		dSP6-16
<i>TM1S</i>	TM1S	1st soak segment time	Sets the 1st soak segment time.	0 to 99h59m	0.00		dSP6-32

Note 1: When a customer does not specify the settings while ordering, the following settings are selected as factory defaults.

Thermocouple input : Thermocouple K Measured range: 0 to 400°C
Resistance bulb input : Measured range: 0 to 150°C
Voltage/Current input : Scaling: 0 to 100%

[9] Parameter table

Parameter table PXR (3/4)



•Parameters of the second block

Parameter display symbol	Parameter name		Description	Setting range	Value prior to delivery	User's set value	Parameter mask DSP
<i>Sv-2</i>	Sv-2	2nd target SV	Sets the 2nd target SV of ramp-soak operation.	Within the SV limit.	0%FS		dSP6-64
<i>TM2r</i>	TM2r	2nd ramp segment time	Sets the 2nd ramp segment time.	0 to 99h59m	0.00		dSP6-128
<i>TM2S</i>	TM2S	2nd soak segment time	Sets the 2nd soak segment time.	0 to 99h59m	0.00		dSP7-1
<i>Sv-3</i>	Sv-3	3rd target SV	Sets the 3rd target SV of ramp-soak operation.	Within the SV limit.	0%FS		dSP7-2
<i>TM3r</i>	TM3r	3rd ramp segment time	Sets the 3rd ramp segment time.	0 to 99h59m	0.00		dSP7-4
<i>TM3S</i>	TM3S	3rd soak segment time	Sets the 3rd soak segment time.	0 to 99h59m	0.00		dSP7-8
<i>Sv-4</i>	Sv-4	4th target SV	Sets the 4th target SV of ramp-soak operation.	Within the SV limit.	0%FS		dSP7-16
<i>TM4r</i>	TM4r	4th ramp segment time	Sets the 4th ramp segment time.	0 to 99h59m	0.00		dSP7-32
<i>TM4S</i>	TM4S	4th soak segment time	Sets the 4th soak segment time.	0 to 99h59m	0.00		dSP7-64
<i>Sv-5</i>	Sv-5	5th target SV	Sets the 5th target SV of ramp-soak operation.	Within the SV limit.	0%FS		dSP7-128
<i>TM5r</i>	TM5r	5th ramp segment time	Sets the 5th ramp segment time.	0 to 99h59m	0.00		dSP8-1
<i>TM5S</i>	TM5S	5th soak segment time	Sets the 5th soak segment time.	0 to 99h59m	0.00		dSP8-2
<i>Sv-6</i>	Sv-6	6th target SV	Sets the 6th target SV of ramp-soak operation.	Within the SV limit.	0%FS		dSP8-4
<i>TM6r</i>	TM6r	6th ramp segment time	Sets the 6th ramp segment time.	0 to 99h59m	0.00		dSP8-8
<i>TM6S</i>	TM6S	6th soak segment time	Sets the 6th soak segment time.	0 to 99h59m	0.00		dSP8-16
<i>Sv-7</i>	Sv-7	7th target SV	Sets the 7th target SV of ramp-soak operation.	Within the SV limit.	0%FS		dSP8-32
<i>TM7r</i>	TM7r	7th ramp segment time	Sets the 7th ramp segment time.	0 to 99h59m	0.00		dSP8-64
<i>TM7S</i>	TM7S	7th soak segment time	Sets the 7th soak segment time.	0 to 99h59m	0.00		dSP8-128
<i>Sv-8</i>	Sv-8	8th target SV	Sets the 8th target SV of ramp-soak operation.	Within the SV limit.	0%FS		dSP9-1
<i>TM8r</i>	TM8r	8th ramp segment time	Sets the 8th ramp segment time.	0 to 99h59m	0.00		dSP9-2
<i>TM8S</i>	TM8S	8th soak segment time	Sets the 8th soak segment time.	0 to 99h59m	0.00		dSP9-4
<i>Mod</i>	Mod	Ramp-soak mode	Selects the power-on start, repeat, and standby functions for ramp-soak operations.	0 to 15	0		dSP9-8

•Parameters of the third block

Parameter display symbol	Parameter name		Description	Setting range	Value prior to delivery	User's set value	Parameter mask DSP
<i>P-n1</i>	P-n1	Control action	Specifies control action and output at the input burn-out.	0 to 19	0/4		dSP9-16
<i>Sv-L</i>	Sv-L	SV (Setting value) lower limiter	Sets the lower limit of the SV.	0 to 100%FS	0%FS		dSP9-32
<i>Sv-H</i>	Sv-H	SV (Setting value) upper limiter	Sets the upper limit of the SV.	0 to 100%FS	100%FS		dSP9-64
<i>dLY1</i>	dLY1	Delay time 1	Delay time or timer value for alarm 1 relay.	0 to 9999 seconds	0		dSP9-128
<i>dLY2</i>	dLY2	Delay time 2	Delay time or timer value for alarm 2 relay.	0 to 9999 seconds	0		dSP10-1
<i>dLY3</i>	dLY3	Delay time 3	Delay time or timer value for alarm 3 relay.	0 to 9999 seconds	0		dSP10-2
<i>CT</i>	CT	Current transe display	Displays the current detector input value for HB alarm.	-	-		dSP10-4

Parameter table PXR (4/4)

•Parameters of the third block

Parameter display symbol	Parameter name		Description	Setting range	Value prior to delivery	User's set value	Parameter mask DSP
Hb	Hb	HB (Set value of heater break alarm) setting	Sets the operation value that detects the heater break.	0 to 50.0A (Setting to 0.0A turns off the HB alarm.)	0.0		dSP10-8
A1hY	A1hY	Alarm 1 hysteresis	Sets the hysteresis range of ON and OFF of alarm 1.	0 to 50%FS	1		dSP10-16
A2hY	A2hY	Alarm 2 hysteresis	Sets the hysteresis range of ON and OFF of alarm 2.	0 to 50%FS	1		dSP10-32
A3hY	A3hY	Alarm 3 hysteresis	Sets the hysteresis range of ON and OFF of alarm 3.	0 to 50%FS	1		dSP10-64
A1oP	A1oP	Alarm 1 options	Sets the optional functions of alarms 1 and 2. 8888 Alarm latch (1: use, 0: not use) Alarm of error status (1: use, 0: not use) De-energized output (1: use, 0: not use)	000 to 111	000		dSP10-128
A2oP	A2oP	Alarm 2 options		000 to 111	000		dSP11-1
A3oP	A3oP	Alarm 3 options		000 to 111	000		dSP11-2
PLC1	PLC1	Lower limit for output 1	Sets the lower limit for output 1.	-3.0 to 103.0%	-3.0		dSP11-4
PHC1	PHC1	Upper limit for output 1	Sets the upper limit for output 1.	-3.0 to 103.0%	103.0		dSP11-8
PLC2	PLC2	Lower limit for output 2	Sets the lower limit for output 2.	-3.0 to 103.0%	-3.0		dSP11-16
PHC2	PHC2	Upper limit for output 2	Sets the upper limit for output 2.	-3.0 to 103.0%	103.0		dSP11-32
PCUT	PCUT	Output limit types	Sets the limit types of outputs 1 and 2 (breaking the limit, or maintained within the limit).	0 to 15	0		dSP11-64
oUT1	oUT1	Output value (MV) display	Displays the value of output 1.	-	-		dSP11-128
oUT2	oUT2	Output value (MV) display	Displays the value of output 2.	-	-		dSP12-1
rCJ	rCJ	RCJ (Cold junction compensation) setting	Sets the cold junction compensation function to ON/OFF.	ON: Performs the RCJ (Cold junction compensation). OFF: Does not perform the RCJ (Cold junction compensation).	on		dSP12-2
GAIN	GAIN	PV gradient		0.001 to 2.000	1.000		dSP12-4
AdJ0	AdJ0	User-definable zero adjustment	Shifts the zero point of input value.	-50 to 50%FS	0		dSP12-8
AdJS	AdJS	User-definable span adjustment	Shifts the span of input value.	-50 to 50%FS	0		dSP12-16
di-1	di-1	DI1 (Digital input 1) operation	Sets the DI1 operations.	0 to 12	0		dSP12-32
di-2	di-2	DI2 (Digital input 2) operation	Sets the DI2 operations.	0 to 12	0		dSP12-64
STno	STno	Station No.	Sets the station No. for communication.	0 to 255	1		dSP12-128
CoM	CoM	Parity setting	Sets the parity for communication. (The baud rate is fixed at 9600bps.)	0: Odd parity 1: Even parity 2: No parity	0		dSP13-1
PCoL	PCoL	Communication protocol setting	Switches communication protocol between Modbus and ASCII.	0: Z-ACSII 1: Modbus (RTU)	Depends on the type.		dSP13-2
Ao-T	Ao-T	Re-transmission output type	Selecting re-transmission output type.	0: PV / 1: SV / 2: MV / 3: DV	0		dSP13-4
Ao-L	Ao-L	Re-transmission base scale	Setting re-transmission base scale.	-100.0 to 100.0%	0.0		dSP13-4
Ao-H	Ao-H	Re-transmission span scale	Setting re-transmission span scale.	-100.0 to 100.0%	100.0		dSP13-4
rENO	rENO	Remote SV input zero adjustment	Shifts the zero point of input value.	-50 to 50%FS	0		dSP13-16
rENS	rENS	Remote SV input span adjustment	Shifts the span point of the input value.	-50 to 50%FS	0		dSP13-16
r-dF	r-dF	Remote SV input filter constant	Sets the filter constant of remote SV input value.	0.0 to 900.00 seconds	0.0		dSP13-16
rSv	rSv	Remote SV input value display	Displays the input value of remote SV input.	-	-		dSP13-16
dSP1 dSP9 dP10 dP13	dSP1 dSP9 dP10 dP13	Parameter mask	Sets whether or not to display each parameter.	0 to 255		Ordering specification	-

Micro Controller PXW,PXZ,PXV

PXW of 3-key type

● Standard type

48X48mm



PXW4

72X72mm



PXW7

● Front waterproof type

48X48mm



PXW4

72X72mm



PXW7

PXZ of 8-key type

● Standard type

48X48mm



PXZ4

72X72mm



PXZ7

● Front waterproof type

48X48mm



PXZ4

72X72mm



PXZ7

Rail mounting types (PXW4, PXZ4, PXV4)

48X48mm



PXW4

48X48mm



PXZ4

48X48mm



PXV4

PXV of 1-stage display and 3-key type

● Standard type

48X48mm



PXV4

● Front waterproof type

48X48mm



PXV4

Features

● Fuzzy control

Excellent controllability is ensured unaffected by overshoot and external disturbance.

Fuzzy control

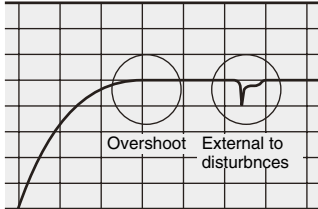

With conventional control Overshoot

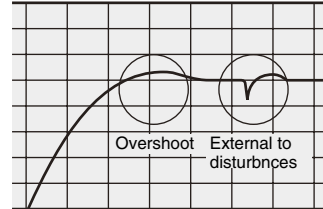

● Heater burnout alarm (option)

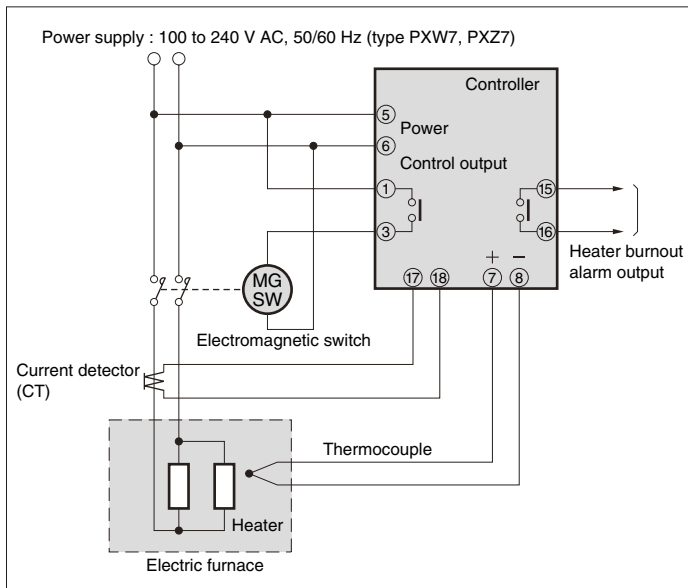

● Ramp/soak function (option)

Control follows the predetermined SV.

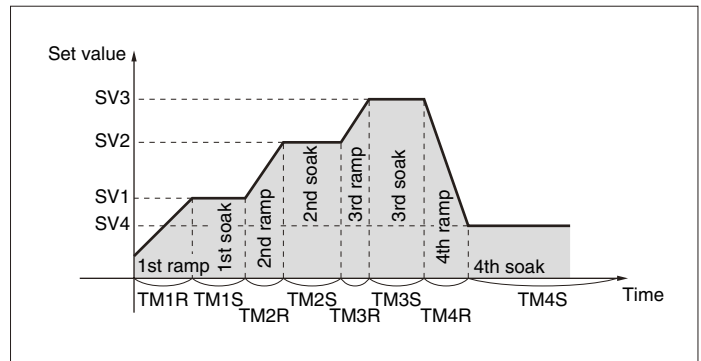

● Free line voltage

100 to 240 V AC or 24 V DC/AC line has been prepared.

● Heating and cooling control (option)

A single controller can issue both control outputs for heating and cooling.

● PID with auto tuning

Standard-provided with auto tuning function for calculation of optimum PID parameters.



[2] Specifications PXW/PXZ/PXV

■ Control function — Standard type

Control action	PID control with auto-tuning / auto-tuning with Fuzzy control
Proportional band(P)	0 to 999.9% of measuring range, setting in 0.1% steps
Integral time(I)	0 to 3200sec, setting in 1sec step
Differential time(D)	0 to 999.9%, setting in 0.1% steps
P=0:2-position action I,D=0:Proportional action	
Proportional cycle	1 to 150sec, setting in 1sec step, relay contact output, SSR/SSC drive output only
Hysteresis width	1 to 50% of measuring range, 2-position action only
Anti-reset wind up tuning	0 to 100% of measuring range, auto setting with auto-tuning
Input sampling cycle	0.5sec
Control cycle	0.5sec

■ Control function — Heating/cooling type (option)

Heating proportional band(P)	0 to 999.9% of measuring range
Cooling proportional band(P)	Heating proportional band X cooling proportional band coefficient Cooling proportional band coefficient=0 to 100.0 0:ON/OFF action
Integral time(I)	0 to 3200sec for heating and cooling
Differential time(D)	0 to 999.9sec for heating and cooling
P,I,D=0:ON/OFF action (without dead band) for heating and cooling I,D=0:Proportional action	
Proportional cycle	1 to 150sec, relay contact output, SSR/SSC drive only
Hysteresis width	ON/OFF action for heating and cooling:0.5% of measuring range
Anti-reset wind up	0 to 100% of measuring range, auto setting with auto-tuning
Overlap/dead band	±50% of heating proportional band
Input sampling cycle	0.5sec
Control cycle	0.5sec

■ Input

Input signal	Thermocouple : J K R B S T E N PLII Resistance bulb : Pt100 Voltage/current : 1 to 5V DC 4 to 20mA DC (Current input is used with supplied 250Ω external resistor)
Measuring range	See Measuring range table.
Burnout	For thermocouple/resistance bulb input, control output over scale direction is selectable upper side or lower side

■ Output — Standard type

Control output	1 of the following 3 types is selected. Relay contact (SPDT contact): 220V AC/30V DC, 3A (resistive load) Mechanical life:10 million cycles or more (no load) Electrical life:100 thousand cycles or more (rated load) Minimum switching current:100mA (24V DC) SSR/SSC drive (voltage pulse): 15 to 30V DC at ON/ 0.5V DC or less at OFF, Max. current: 60mA or less 25mA(With alarm 2points on 48X48mm size) 30mA(at 24V DC/24V AC supply voltage) 4 to 20mA DC:Allowable load resistance: 600Ω or less
-----------------------	--

■ Output — Heating/cooling type (option)

Control output	For dual output type, 1 of the following 3 types is selected on both heating and cooling types. 48 X 48mm type is not acceptable. Relay contact (SPDT contact): 220V AC/30V DC, 3A (resistive load) Mechanical life:10 million cycles or more (no load) Electrical life:100 thousand cycles or more (rated load) Minimum switching current:100mA (24V DC) SSR/SSC drive (voltage pulse): 15 to 30V DC at ON/ 0.5V DC or less at OFF, Max. current is 60mA or less. 4 to 20mA DC:Allowable load resistance; 600Ω or less (Note) When SSR/SSC drive output of heating/cooling side is selected, the total current should be less than 60mA.
-----------------------	--

■ Setting and indication

Parameter setting method	PXV/PXW; digital setting with 3 keys PXZ; digital setting with 8 keys
PV/SV display method	PXV4, PXZ4; PV/SV select display LED; 4 digits, red PXW, PXZ7; PV/SV individual display LED, 4 digits each, PV; red SV; green
Status display	Control output, alarm output heater burnout alarm output, LED lamp (red)
Setting accuracy	0.1% of measuring range or less
Indication accuracy (at 23°C):	Thermocouple; ±(0.5% of measuring range) ±1digit ±1°C R thermocouple 0 to 500°C; ±(1% of measuring range) ±1digit ±1°C B thermocouple 0 to 400°C; ±(5% of measuring range) ±1digit ±1°C Resistance bulb, voltage, current; ±(0.5% of measuring range) ±1digit

■ Alarm (option)

Kind of alarm	See table "Kind of alarm".
Alarm output	Relay contact (SPST contact), 220V AC /30V DC, 1A (resistive load), Mechanical life:10 million cycles or more (no load) Electrical life:100 thousand cycles or more (rated load) Minimum switching current:100mA (24V DC) 48X48mm type; output..1point or 2points Other types; output..2points
Heater burnout alarm output	Relay contact (SPST contact), 220V AC/30V DC, 1A (resistive load) Mechanical life:10 million cycles or more (no load) Electrical life:100 thousand cycles or more (rated load) Minimum switching current:100mA (24V DC) 48X48mm type; not available, output; 1 point

■ Power failure processing

Memory protection	Non-volatile memory hold After the recovery of power from failure, control is started at the value before power failure.
--------------------------	---

■ Self-check

Method	Monitoring of program error with watchdog timer
---------------	---

■ Operation and storage condition

Operating temperature	-10 to 50°C
Operating humidity	90%RH or less (Non condensing)
Storage temperature	-20 to 60°C

[2] Specifications PXW/PXZ/PXV

■ General specifications

Rated voltage	100 (-15%) to 240 (+10%) V AC 50/60Hz, 24V AC ($\pm 10\%$) 50/60Hz, 24V DC ($\pm 10\%$)
Power consumption	10VA or less (100V AC) 15VA or less (240V AC, 24V AC, 24V DC)
Insulation resistance	20M Ω or more (500V DC)
Withstand voltage	Power source-Earth, 1500V AC, 1min Power source-Other, 1500V AC, 1min Earth-Relay output, 1500V AC, 1min Earth-Alarm output, 1500V AC, 1min Other, 500V AC, 1min
Input impedance	Thermocouple; 1M Ω or more Voltage; 400k Ω or more Current; 250 Ω (external resistor)
Allowable signal source resistance	Thermocouple; 100 Ω or less Voltage; 1k Ω or less
Allowable wiring resistance	Resistance bulb; 10 Ω or less per wire
Reference junction compensation accuracy	$\pm 1^\circ\text{C}$; (at 23 $^\circ\text{C}$)
PV offset	$\pm 10\%$ of measuring range
SV offset	$\pm 50\%$ of measuring range
Input filter	0 to 900.0sec, setting in 0.1sec steps (primary lagging filter)
Noise reduction ratio	Normal mode noise (50/60Hz) ;50dB or more Common mode noise (50/60Hz) ;140dB or more

■ Other functions

Parameter mask function	Parameter display is disabled by software.
Ramp soak function(option)	4 ramp/4 soak
Heater burnout alarm output (option) unavailable for 48 X 48 size	Current detector: CTL-6-S-H for 1 to 30A CTL-12-S36-8F for 20 to 50A Alarm settable range: 1 to 50A Set the parameter "TC" more than 20 sec, or heater burnout function doesn't work correctly.
Applicable standards	UL, C-UL, CE mark

■ Structure

Mounting method	Panel flush mounting or surface mounting Surface mounting; 48X48mm type only
External terminal	48X48mm type; 8-pin or 11-pin socket Other types; screw terminal (M3.5 screw)
Case material	Plastic
External dimensions	See outline diagram.
Mass	48X48mm; approx 150g 72X72mm; approx 300g
Protective structure	Front panel water-proof structure; NEMA4X (equivalent to IEC standards IP66)(option) Rear case; IEC IP20
Enclosure color	Standard type; ivory (front panel, case) Water-proof type; black (front panel, case)

■ Scope of delivery

Standard type	48X48mm type; controller, panel mounting bracket, socket (when specified), instruction manual 1 volume Other types; controller, panel mounting bracket, instruction manual 1 volume
Water-proof type	48X48mm type; controller, panel mounting bracket, socket (when specified), water-proof packing, instruction manual 1 volume Other types; controller, panel mounting bracket, water-proof packing, instruction manual 1 volume

■ Measuring range table

Input signal	Input range($^\circ\text{C}$)	Input range($^\circ\text{F}$)
Resistance bulb		
Pt100 Ω	0 to 150	32 to 302
Pt100 Ω	0 to 300	32 to 572
Pt100 Ω	0 to 500	32 to 932
Pt100 Ω	0 to 600	32 to 1112
Pt100 Ω	-50 to 100	-58 to 212
Pt100 Ω	-100 to 200	-148 to 392
Pt100 Ω	-150 to 600	-238 to 1112
Pt100 Ω	-150 to 850	-238 to 1562
Thermocouple		
J	0 to 400	32 to 752
J	0 to 800	32 to 1472
K	0 to 400	32 to 752
K	0 to 800	32 to 1472
K	0 to 1200	32 to 2192
R	0 to 1600	32 to 2912
B	0 to 1800	32 to 3272
S	0 to 1600	32 to 2912
T	-199 to 200	-328 to 392
T	-150 to 400	-238 to 752
E	0 to 800	32 to 1472
E	-199 to 800	-328 to 1472
N	0 to 1300	32 to 2372
PLII	0 to 1300	32 to 2372
DC voltage 1 to 5V DC	Scaling range; -1999 to 9999	
DC current 4 to 20mA DC	For current input, use a 250 resistor to obtain 1 to 5V DC input.	

Note) Input signals can be selected within the same type.
It is impossible to select input signals of a different type.



Micro Controller PXW, PXZ, PXV

[3]-1 Outline diagram/panel cut [Standard type]

1) 48 × 48mm type

(unit: mm)

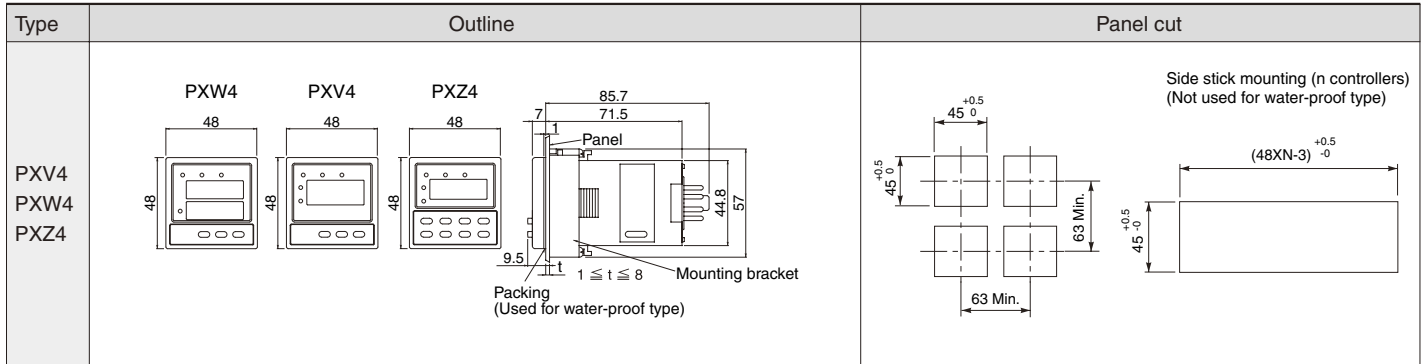

Note) PXV4, PXW4 and PXZ4 are common to standard types and water-proof types.

2) 72 × 72mm type

(unit: mm)

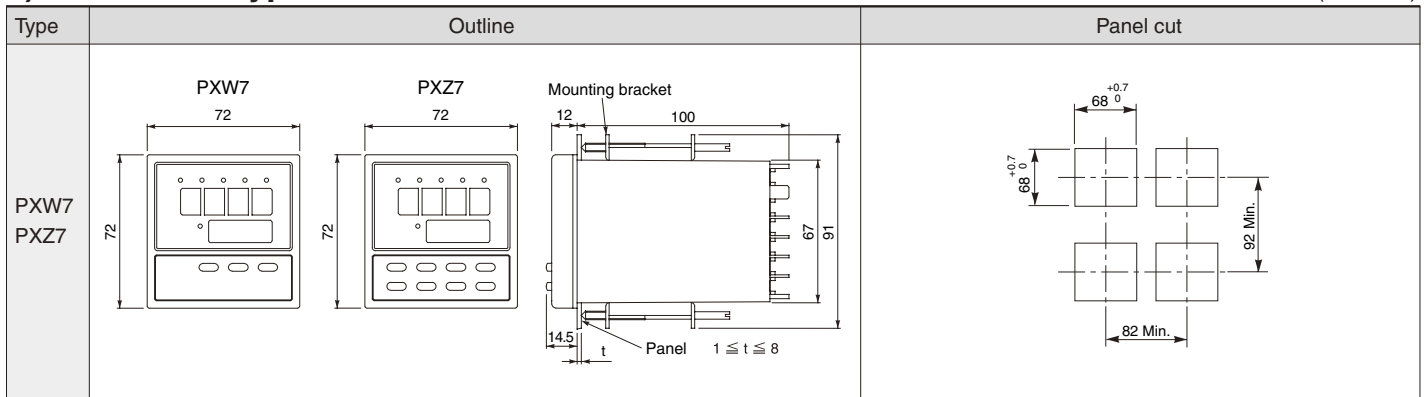

[3]-2 Outline diagram/panel cut [Water-proof type]

1) 72 × 72mm type

(unit: mm)

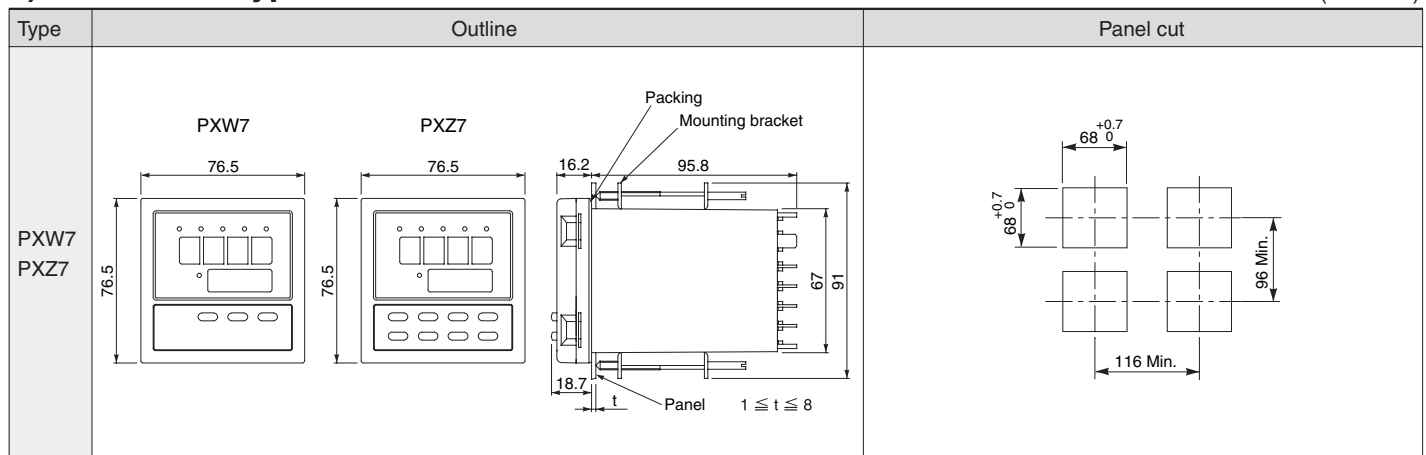

[4]-1 Connection diagram [for 100 to 240V AC power supply]

1) PXW4 · PXZ4 · PXV4 type

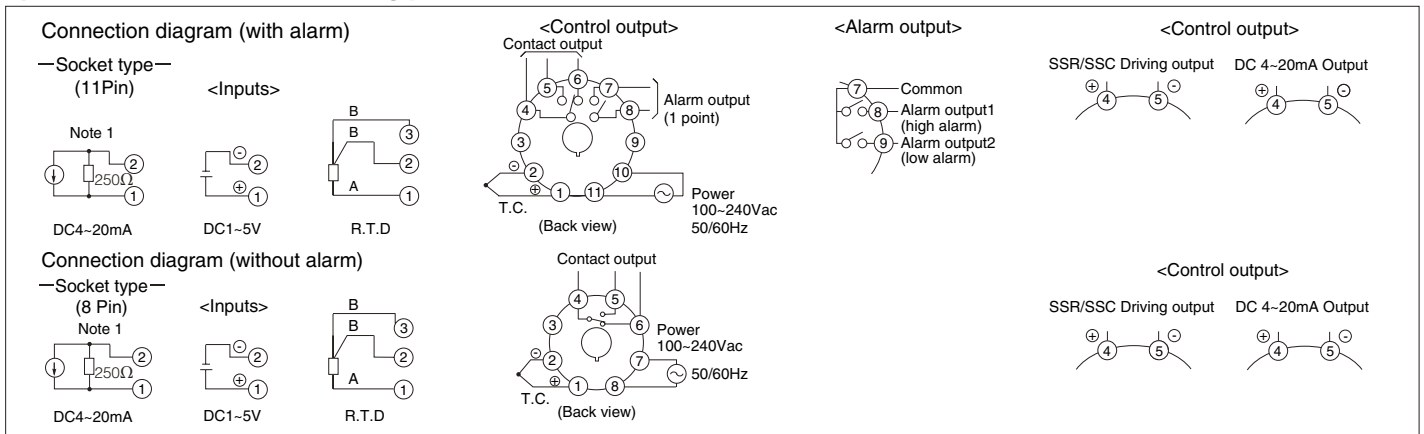

Note1: Use the 250Ω resistance(accessory).

Note2: SSR/SSC drive output and DC4-20mA output are not electrically insulated from inner circuits. So, non-grounding type sensor must be used.

2) PXW7 · PXZ7 type

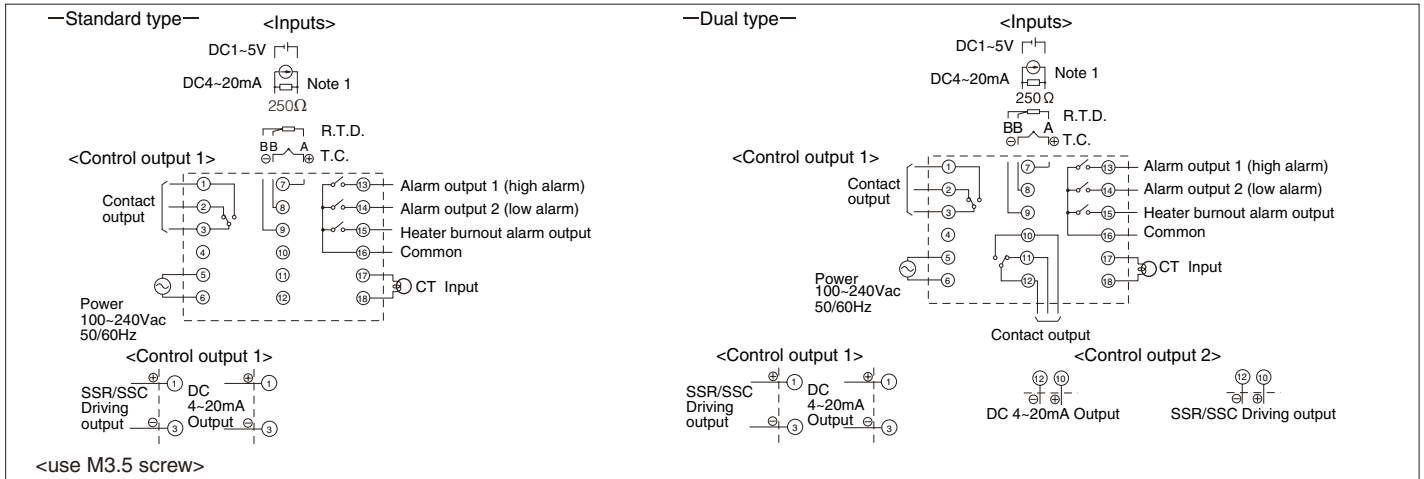

Note1: Use the 250Ω resistance(accessory).

Note2: SSR/SSC drive output and DC4-20mA output are not electrically insulated from inner circuits. So, non-grounding type sensor must be used.

[4]-2 Connection diagram [for 24V DC/24V AC power supply]

1) PXW4 · PXZ4 · PXV4 type

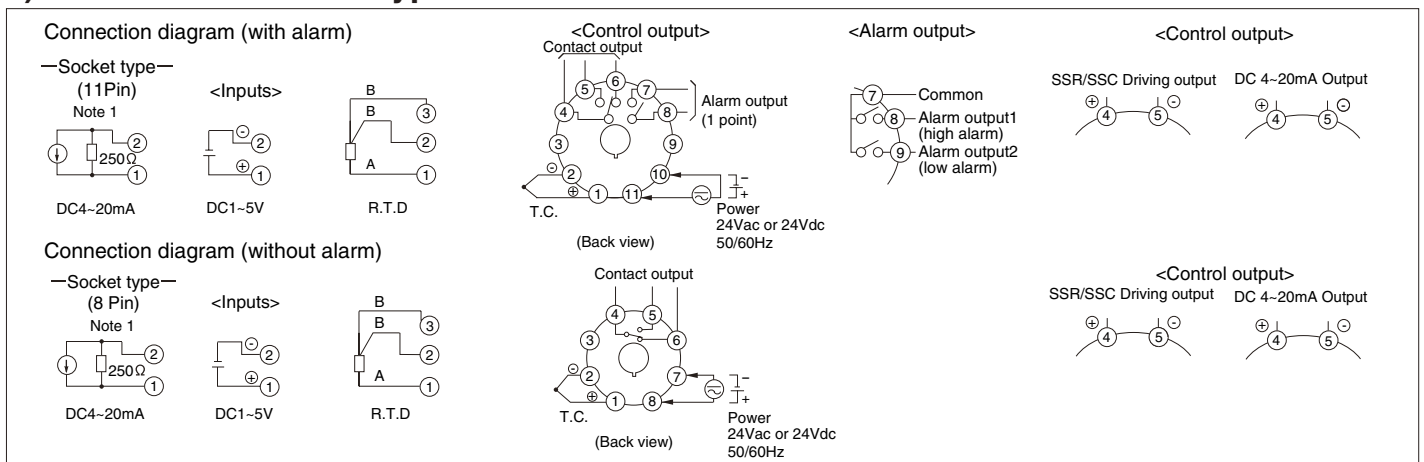

Note1: Use the 250Ω resistance(accessory).

Note2: SSR/SSC drive output and DC4-20mA output are not electrically insulated from inner circuits. So, non-grounding type sensor must be used.

⚠ Caution: Before connection to each controller, carefully check the voltage and polarities of the power supply to be used. The above connections correspond to 24 V AC or DC. If power supply within 100 to 240 V is connected, each controller will be permanently damaged and will not operate.

Micro Controller PXW,PXZ,PXV

[5] Socket outline diagram [PXW4,PXZ4,PXV4 type]

Without alarm

ATX1NS type (US socket)

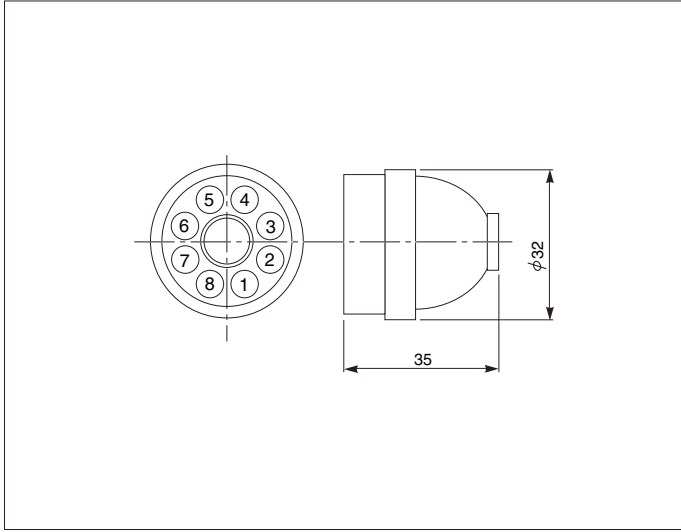

With alarm

TP411X type (rail mounting)

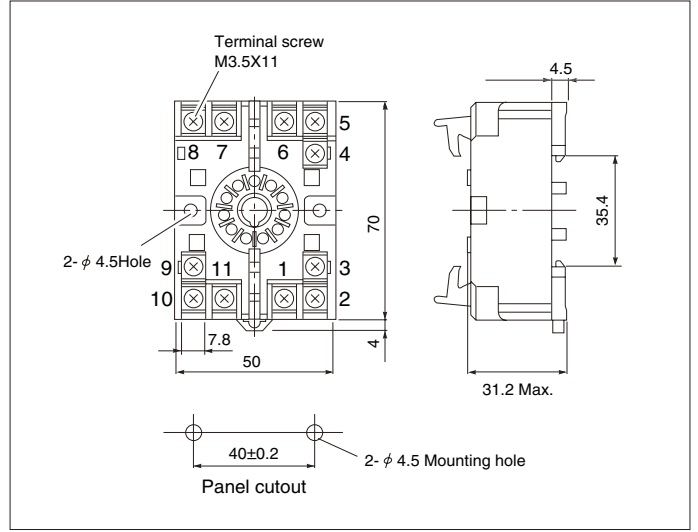

TP48SB type (back screw wiring)

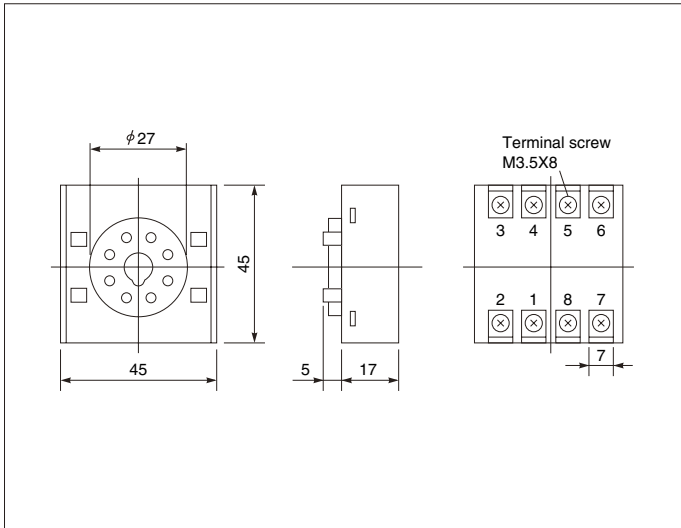

TP411SBA type (mounting panel)

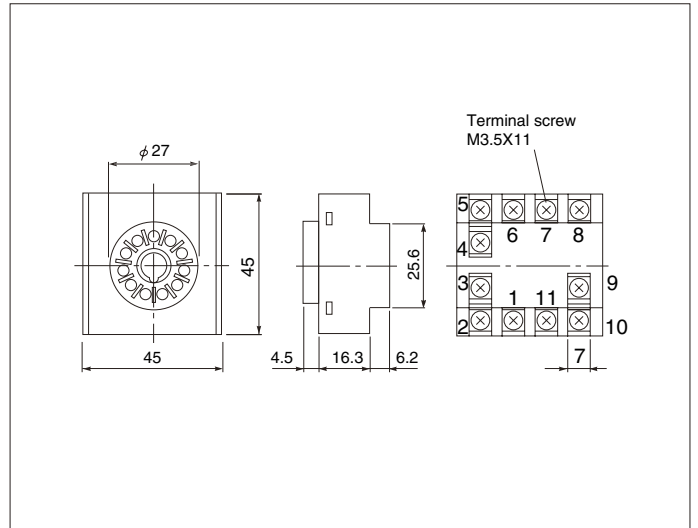

TP48X type (rail mounting)

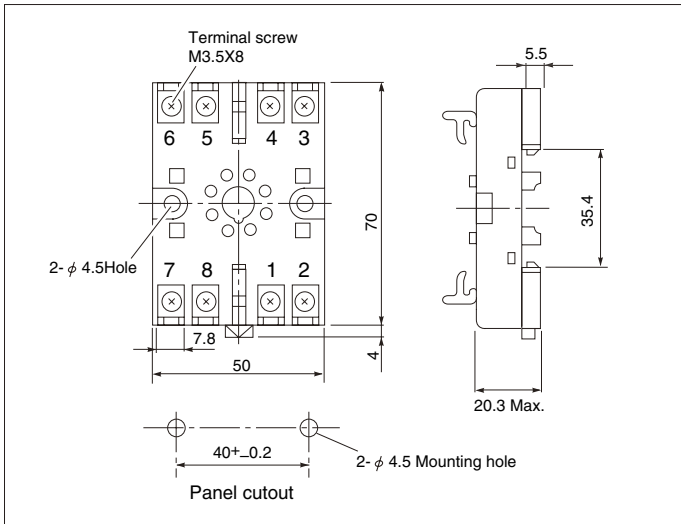

Appearance of various sockets

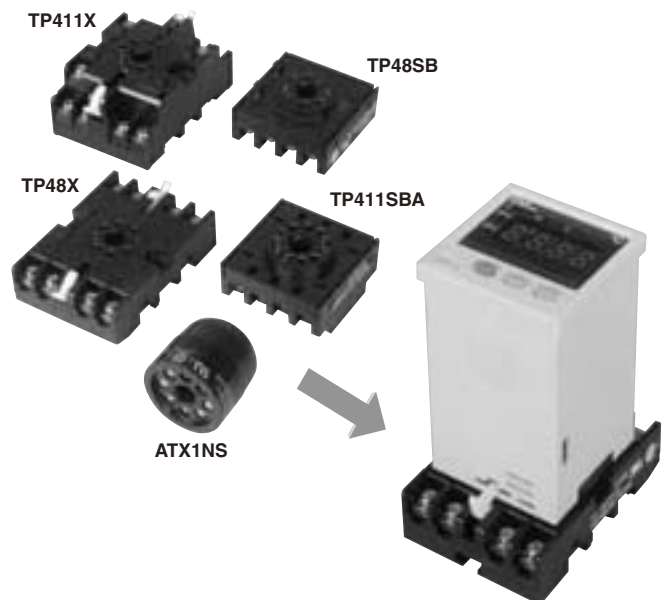

[6] Alarm code table

Alarm

- Kind of alarm and alarm type code

	P-AH (ALM1)	P-AL (ALM2)	Kind of alarm	Action diagram
	0	0	Without alarm	
Absolute alarm	1	1	High absolute alarm	
	2	2	Low absolute alarm	
	3	3	High absolute alarm (with hold)	
	4	4	Low absolute alarm (with hold)	
Deviation alarm	5	5	High deviation alarm	
	6	6	Low deviation alarm	
	7	7	High/low deviation alarm	
	8	8	High deviation alarm (with hold)	
	9	9	Low deviation alarm (with hold)	
	10	10	High/low deviation alarm (with hold)	
Zone	11	11	High/low range deviation alarm (ALM1/2 individual action)	
	-	12	High/low range absolute alarm	
	-	13	High/low range deviation alarm	
	-	14	High range absolute alarm and low range deviation alarm	
	-	15	High range deviation alarm and low range absolute alarm	

Note: (1) Alarm output is ON in the alarm band marked

(2) What is alarm with hold?

The alarm is not turned ON immediately even when the measured value is in the alarm band. It turns ON when it goes out the alarm band and enters again.

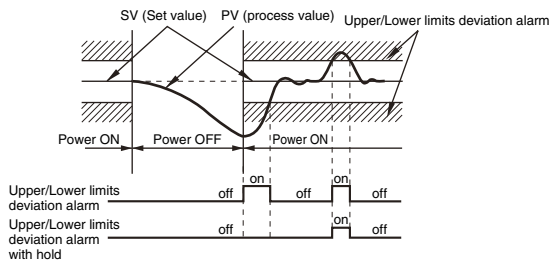

Reference data

Comparison of the alarm code with conventional types
Conversion table for PYZ/W series "P-Ab" and PX series "P-AH" "P-AL"

- Alarm code conversion table (PYV/W/Z → PXV/W/Z)

Kind of alarm	PXV/W/Z code	PXV/W/Z code	
	P-Ab	P-AH	P-AL
High deviation alarm	10	5	0
Low deviation alarm	5	0	6
Low deviation alarm with hold	69	0	9
High/low deviation alarm	15	5	6
High/low deviation alarm with hold	79	5	9
High-high absolute alarm	19	1	1
High absolute alarm	2	1	0
Low absolute alarm	1	0	2
Low absolute alarm with hold	65	0	4
High/low absolute alarm	3	1	2
High/low absolute alarm with hold	67	1	4
High absolute high deviation alarm	23	1	5
High absolute low deviation alarm	7	1	6
High deviation low absolute alarm	11	5	2
High deviation low absolute alarm with hold	75	5	4
High absolute low deviation alarm with hold	71	1	9
High/low absolute range alarm	179	-	12
High/low deviation range alarm	191	-	13
High absolute low deviation range alarm	183	-	14
High deviation low absolute range alarm	187	-	15

Heater burnout alarm current detector (CT)

- Specification : For 20-50A
- Type : CTL-12-S36-8F

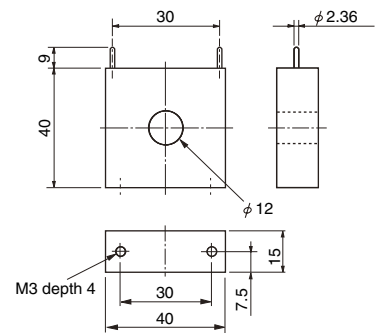

- Specification : For 1-30A
- Type : CTL-6-S-H

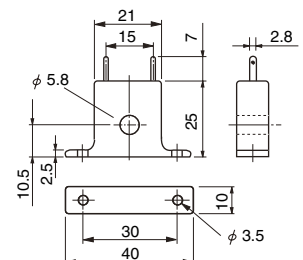

Micro Controller PXW,PXZ,PXV

[7] Parameter table



PXW/PXV parameter table

Note : Figure with %* table below means “% of measuring range”.

	Parameter	Setting range	Meaning of parameter	Unit	Value prior to delivery	User's set value	DSP assignment
No.1 block parameter	PRoG	roFF/rrUn/rHLd	Ramp soak control (start/stop/pause)	—	—		dsp1-1
	H	0-100%*	High alarm (ALM1) set value	Industrial/deviation industrial value	10		dsp1-2
	L	0-100%*	Low alarm (ALM2) set value	Industrial/deviation industrial value	10		dsp1-4
	HB	0.0-50.0	Heater burnout detect value setting (function OFF at 0)	A (ampere)	0.0		dsp1-8
	AT	0-2	Auto-tuning command (0:OFF/1:Standard/2:Low PV)	—	0		dsp1-16
No.2 block parameter	LoC	0-2	Setting lock (0:OFF/1:All lock/2:Lock,other than SV)	—	0		dsp1-32
	P	0.0-999.9	Proportional band (2-position action at 0)	%	5.0		dsp1-128
	I	0-3200	Integral time (integration OFF at 0)	Second	240		dsp2-1
	D	0.0-999.9	Differential time (Differentiation OFF at 0)	Second	60.0		dsp2-2
	TC	1-150	Output 1 proportional cycle (RY:30/SSR:2/4 to 20mA:0)	Second	30/2/0		dsp2-4
	HYS	0-50%*	2-position action hysteresis	Deviation industrial value	1		dsp2-8
	TC2	1-150	Output 2 proportional cycle (RY:30/SSR:2/4 to 20mA:0)	Second	30/2/0		dsp2-16
	CooL	0.0-100.0	Cooling side proportional band coefficient	—	1.0		dsp2-32
	db	-50.0-50.0	Dead band	%	0.0		dsp2-64
	bAL	-100.0-100.0	Manual reset value (single 0.0/dual 50.0 prior to delivery)	%	0.0/50.0		dsp2-128
	Ar	0-100%*	Anti-reset wind up (100%* prior to delivery)	Deviation industrial value	100%*		dsp3-1
	P-n2	0-16	Input type code	—	Ordering specification		dsp3-2
	P-SL	-1999-9999	0% input scale	Industrial value	Ordering specification Note3)		dsp3-4
	P-SU	-1999-9999	100% input scale	Industrial value	Ordering specification Note3)		dsp3-8
	P-dP	0-2	Decimal point position code (0:□□□/1:□□□/2:□□□)	—	Ordering specification Note3)		dsp3-16
	P-AH	0-11	High (ALM2) type code	—	Ordering specification		dsp3-32
	P-AL	0-15	Low (ALM1) type code	—	Ordering specification		dsp3-64
	PVOF	-10-10%*	Input bias	Deviation industrial value	0		dsp3-128
	SVOF	-50-50%*	Set value bias	Deviation industrial value	0		dsp4-1
	P-F	℃/F	℃/F designation	—	Ordering specification		dsp4-2
	STAT	...	Ramp soak present position	—	—		dsp4-4
	SV-1	0-100%*	No.1 target value	Industrial value	0% Note5)		dsp4-8
	TM1r	0-99h59m	No.1 ramp segment time	Hour/minute	0.00		dsp4-16
	TM1S	0-99h59m	No.1 soak segment time	Hour/minute	0.00		dsp4-32
	SV-2	0-100%*	No.2 target value	Industrial value	0% Note5)		dsp4-64
	TM2r	0-99h59m	No.2 ramp segment time	Hour/minute	0.00		dsp4-128
	TM2S	0-99h59m	No.2 soak segment time	Hour/minute	0.00		dsp5-1
	SV-3	0-100%*	No.3 target value	Industrial value	0% Note5)		dsp5-2
TM3r	0-99h59m	No.3 ramp segment time	Hour/minute	0.00		dsp5-4	
TM3S	0-99h59m	No.3 soak segment time	Hour/minute	0.00		dsp5-8	
SV-4	0-100%*	No.4 target value	Industrial value	0% Note5)		dsp5-16	
TM4r	0-99h59m	No.4 ramp segment time	Hour/minute	0.00		dsp5-32	
TM4S	0-99h59m	No.4 soak segment time	Hour/minute	0.00		dsp5-64	
Mod	0-15	Control designation before and after ramp soak	—	0 Note4)		dsp5-128	
No.3 block parameter	P-n1	0-19	Control type code	—	Ordering specification		dsp6-2
	P-dF	0.0-900.0	Input filter time constant (filter OFF at 0)	Second	5.0		dsp6-4
	P-An	0-50%*	Alarm hysteresis	Deviation industrial value	1		dsp6-8
	PLC1	-3.0-103.0	Output 1 minimum ON pulse width	%	-3.0		dsp6-32
	PHC1	-3.0-103.0	Output 1 minimum OFF pulse width	%	103.0		dsp6-64
	PLC2	-3.0-103.0	Output 2 minimum ON pulse width	%	-3.0		dsp6-128
	PHC2	-3.0-103.0	Output 2 minimum OFF pulse width	%	103.0		dsp7-1
	FUZY	OFF/ON	Fuzzy control ON/OFF designation	—	OFF		dsp7-4
	ADJO	-50-50%*	Zero shift	Deviation industrial value	0		dsp7-16
	ADJS	-50-50%*	Span shift	Deviation industrial value	0		dsp7-32
	dSP1-7	0-255	Parameter display mask designation code	—	—		—

Note 1) Items shown in are not indicated at the time of delivery. Note 2) Parameters shown in are indicated in accordance with your model.

Note 3) When you change these value, check all parameter's value after changing these value.

Note 4) Don't change this value from 0 to others. Note5) 0% is equal to the setting value of "P-SL".

[7] Parameter table

PXZ parameter table

Note : Figure with %* table below means "% of measuring range".

	Parameter	Setting range	Meaning of parameter	Unit	Value prior to delivery	User's set value	DSP assignment	
No.1 block parameter	PRoG	oFF/rUn/HLd	Ramp soak control (start/stop/pause)	—	—		dsp1-1	
	P	0.0-999.9	Proportional band (2-position action at 0)	%	5.0		dsp1-2	
	I	0-3200	Integral time (integration OFF at 0)	Second	240		dsp1-4	
	D	0.0-999.9	Differential time (Differentiation OFF at 0)	Second	60.0		dsp1-8	
	AL	0-100%*	Low alarm (ALM2) set value	Industrial/deviation industrial value	10		dsp1-16	
	AH	0-100%*	High alarm (ALM1) set value	Industrial/deviation industrial value	10		dsp1-32	
	TC	1-150	Output 1 proportional cycle (RY:30/SSR:2/4 to 20mA:0)	Second	30/2/0		dsp1-64	
	HYS	0-50%*	2-position action hysteresis	Deviation industrial value	1		dsp1-128	
	Hb	0.0-50.0	Heater burnout detect value setting (function OFF at 0)	A (ampere)	0.0		dsp2-1	
	AT	0-2	Auto-tuning command (0:OFF/1:Standard/2:Low PV)	—	0		dsp2-2	
	TC2	1-150	Output 2 proportional cycle (RY:30/SSR:2/4 to 20mA:0)	Second	30/2/0		dsp2-4	
	Cool	0.0-100.0	Cooling side proportional band coefficient	—	1.0		dsp2-8	
	db	-50.0-50.0	Dead band	%	0.0		dsp2-16	
	PLC1	-3.0-103.0	Output 1 minimum ON pulse width	%	-3.0		dsp2-32	
	PHC1	-3.0-103.0	Output 1 minimum OFF pulse width	%	103.0		dsp2-64	
	bAL	-100.0-100.0	Manual reset value (single 0.0/dual 50.0 prior to delivery)	%	0.0/50.0		dsp3-1	
	Ar	0-100%*	Anti-reset wind up (100%* prior to delivery)	Deviation industrial value	100%*		dsp3-2	
	LoC	0-2	Setting lock (0:OFF/1:All lock/2:Lock,other than SV)	—	0		dsp3-4	
	STAT	...	Ramp soak present position	—	—		dsp3-8	
	SV-1	0-100%*	No.1 target value	Industrial value	0% Note5)		dsp3-16	
	TM1r	0-99h59m	No.1 ramp segment time	Hour/minute	0.00		dsp3-32	
	TM1S	0-99h59m	No.1 soak segment time	Hour/minute	0.00		dsp3-64	
	SV-2	0-100%*	No.2 target value	Industrial value	0% Note5)		dsp3-128	
	TM2r	0-99h59m	No.2 ramp segment time	Hour/minute	0.00		dsp4-1	
	TM2S	0-99h59m	No.2 soak segment time	Hour/minute	0.00		dsp4-2	
	SV-3	0-100%*	No.3 target value	Industrial value	0% Note5)		dsp4-4	
	TM3r	0-99h59m	No.3 ramp segment time	Hour/minute	0.00		dsp4-8	
	TM3S	0-99h59m	No.3 soak segment time	Hour/minute	0.00		dsp4-16	
	SV-4	0-100%*	No.4 target value	Industrial value	0% Note5)		dsp4-32	
	TM4r	0-99h59m	No.4 ramp segment time	Hour/minute	0.00		dsp4-64	
	TM4S	0-99h59m	No.4 soak segment time	Hour/minute	0.00		dsp4-128	
	Mod	0-15	Control designation before and after ramp soak	—	0 Note4)		dsp5-1	
	No.2 block parameter	P-n1	0-19	Control type code	—	Ordering specification		dsp5-4
		P-n2	0-16	Input type code	—	Ordering specification		dsp5-8
		P-dF	0.0-900.0	Input filter time constant (filter OFF at 0)	Second	5.0		dsp5-16
		P-SL	-1999-9999	0% input scale	Industrial value	Ordering specification Note3)		dsp5-32
P-SU		-1999-9999	100% input scale	Industrial value	Ordering specification Note3)		dsp5-64	
P-AL		0-15	Low(ALM1)type code	—	Ordering specification		dsp5-128	
P-AH		0-11	High(ALM2)type code	—	Ordering specification		dsp6-1	
P-An		0-50%*	Alarm hysteresis	Deviation industrial value	1		dsp6-2	
P-dP		0-2	Decimal point position code (0:□□□/1:□□□□/2:□□□□)	—	Ordering specification Note3)		dsp6-4	
PVOF		-10-10%*	Input bias	Deviation industrial value	0		dsp6-16	
SVOF		-50-50%*	Set value bias	Deviation industrial value	0		dsp6-32	
P-F		°C/°F	°C/°F designation	—	Ordering specification		dsp6-64	
PLC2		-3.0-103.0	Output 2 minimum ON pulse width	%	-3.0		dsp6-128	
PHC2		-3.0-103.0	Output 2 minimum OFF pulse width	%	103.0		dsp7-1	
FUZY		OFF/ON	Fuzzy control ON/OFF designation	—	OFF		dsp7-2	
ADJO		-50-50%*	Zero shift	Deviation industrial value	0		dsp7-8	
ADJS		-50-50%*	Span shift	Deviation industrial value	0		dsp7-16	
dSP1-7		0-255	Parameter display mask designation code	—	—		—	

Note 1) Items shown in are not indicated at the time of delivery. Note 2) Parameters shown in are indicated in accordance with your model.
 Note 3) When you change these value, check all parameter's value after changing these value.
 Note 4) Don't change this value from 0 to others. Note5) 0% is equal to the setting value of "P-SL".

Digital Thermostat (type: PAS3)

DIN 24× 48mm size



An alarm setter with on/off contact output.

Most suited for detecting overheat in machines, equipments, etc.

- Front panel having a DIN size of 24 x 48mm.
- Because thermocouples (5 types) and thermistors (0 to 100°C) are connectable.
- Alarm set value and measured temperature value can be checked promptly using the front keys.
- This thermostat is capable of issuing 2 relay contact outputs. Therefore, any output of Upper/Lower limit pair, 2 upper limit and 2 lower limit can be selected.
- Mountable to a DIN rail using the DIN rail mounting adapter available at option. With this adapter, also mountable to a wall.



Specifications

Item	Specification
Input	Number of inputs: 1 Input signal and measurable range: Refer to Table 1. Allowable signal source resistance: Thermocouple input 100Ω max. Measurement cycle: 2 sec. or less Burnout function: Thermocouple input: UUU display Thermistor input: LLL display (Upscale or downscale at burnout settable) Input impedance: Thermocouple input 1 MΩ or higher Input filter: 0 to 90 sec. (settable in 1 sec. steps) Primary lag filter Input value compensation: Settable within ±10% of measurable range
Indication	Indication means: LCD (without back light) Value/parameter indication: 4 digits of 7 segments each (However, at the 1st digit, only - or 1 is indicated within -999 to 1999.) Contents of indication: Measured value, alarm set value 1, alarm set value 2, various parameters Each indicator of alarms 1 and 2, °C scale
Operation	Number of keys: 3 keys, sheet type keys (embossed) Alarm value setting resolution: 1°C Key lock function: (Change of setting can be inhibited.)
Accuracy	Indication accuracy: Refer to Table 1. (However, error of a temperature sensor is not included.) Reference contact compensation error: ±3°C (at 23°C)
Alarm output	Number of outputs: 1 or 2 (as specified in CODE SYMBOLS) Contact structure: 1a contact Alarm type: Refer to Table 2. Contact capacity: 220 V AC/30 V DC, 2 A (resistance load) 220 AC/30 DC, 1 A (inductive load) Mechanical life of contact: 20 million activations or more (100 activations/min.) Electrical life of contact: 100,000 activations or more (rated load) Output resetting cycle: 2 sec. or less Alarm value settable range: Settable within 0 to 100% of measurable range Hysteresis width settable range: 0 to 110% of measurable range (settable in 1°C steps) Alarm action delay time: Settable within 1 to 120 sec.
Power supply	Power supply voltage: 100 V (-15%) to 240 V (+10%) AC 50/60 Hz (±10%) Power consumption: 3 VA max. (with 100 V AC), 6 VA max. (with 240 V AC)
Operating conditions	Ambient temperature: 0 to 50°C Ambient humidity: 90% RH max. (condensation unallowable)
Applicable standards	UL, C-UL, CE mark.
Body structure	Mounting method: Panel flush mounting External dimensions (H x W x D): 24 x 48 x 85 mm Weight: Approx. 100 g Casing material: Plastic (corresponding to flame resistance grade UL94V-0) Front protective structure: IP66 (corresponding to NEMA-4X) when using Fuji's genuine front waterproof packing part External terminals: Plug-in type (for bar terminals) Finish color: Ivory

Alarm output hysteresis width

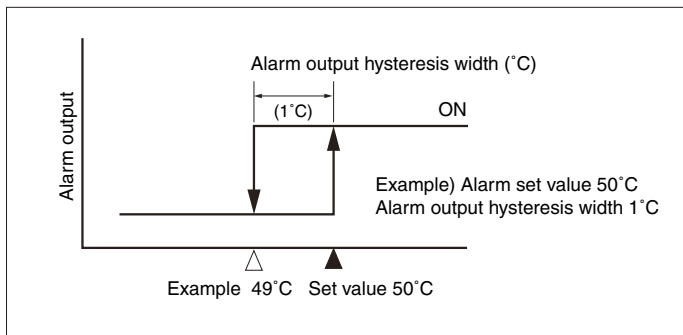

Input signal, measurable range and indication accuracy (Table 1)

Input signal		Measurable range (°C)	Minimum resolution	Indication accuracy
Thermocouple	J	0 to 800	1°C	3°C
	K	0 to 1200	1°C	3°C
	R	0 to 1600	4°C	4°C
	T	0 to 400	1°C	3°C
	E	0 to 600	1°C	3°C
Thermistor	PB-36	0 to 100	1°C	4°C

Note 1) Correct indication is not ensured within a range from 0 to 500°C for an R type thermocouple.

Note 2) Switching between a thermistor and a thermocouple is not allowed. Thermocouple input type can be changed by front key operation.

Alarm types (Table 2)

Code of PA1, 2	Alarm direction	Set value notation	With holding (Note 2)	Relay action at alarm	Action diagram (Note 1)
0	No alarm	-	-	-	—△—→
1	Upper limit	Absolute value	No	Relay excitation	—△—→ [hatched area]
2	Lower limit	Absolute value	No	Relay excitation	[hatched area] —△—→
3	Upper limit	Absolute value	Yes	Relay excitation	—△—→ [hatched area]
4	Lower limit	Absolute value	Yes	Relay excitation	[hatched area] —△—→
5	Upper limit	Absolute value	No	Relay non-excitation	—△—→ [white area]
6	Lower limit	Absolute value	No	Relay non-excitation	[white area] —△—→
7	Upper limit	Absolute value	Yes	Relay non-excitation	—△—→ [white area]
8	Lower limit	Absolute value	Yes	Relay non-excitation	[white area] —△—→

(Note 1) How to read action

[hatched area]: A range in which "ALM1 or ALM2" is indicated on LCD at the front.

[white area]: A range in which alarm relay is excited

△: point: Alarm set value

The horizontal axis represents measured values (PV).

(Note 2) What is the hold function?

Even if the process value is within the alarm range

when turning on power, the alarm does not turn on

immediately but only after it

leaves and then returns to the alarm range.

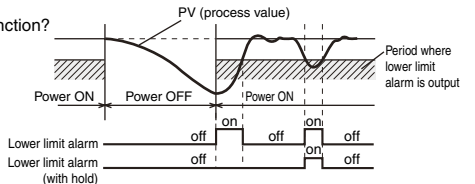

DIN rail mounting

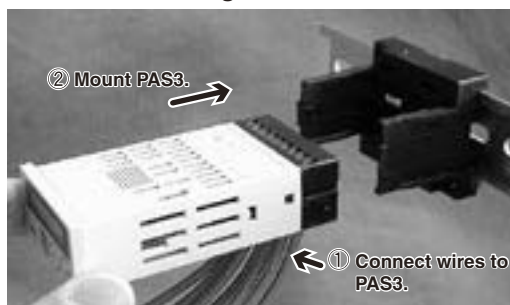

Model

Input signal	Temperature sensor	Number of alarm	Model
Thermocouple	Option	1	PAS3K1Y1
		2	PAS3K1A1
Thermistor	Provided	1	PAS3H1Y1
		2	PAS3H1A1

Optional items

Contents	Model
DIN rail mounting adapter	ZZP*CTK368715P1

Setting at delivery

Measurable range	K thermocouple input (0 to 1200°C) Thermistor input (0 to 100°C)
Alarm set value	K thermocouple input: For 1-point alarm (upper limit 1200°C) K thermocouple input: For 2-point alarm (upper limit 1200°C, lower limit alarm 0°C) Thermistor input: For 1-point alarm (upper limit 100°C) Thermistor input: For 2-point alarm (upper limit 100°C, lower limit alarm 0°C)
Alarm hysteresis width	1°C
Alarm delay time	0 sec.
Indication	Measured value
Burnout	Upscale at burnout
Input filter	5 sec.
Input value compensation	0%

Note 1) Switching between a thermistor and a thermocouple is not allowed.

Note 2) Thermocouple input type can be changed by front key operation.

Scope of delivery

Thermostat unit, panel-mounting adapter,
front waterproof packing
Thermistor sensor added for thermistor input

Attached thermistor sensor

Attachment for thermistor-input thermostat

Measurable range	0 to 100°C
B constant	3390 K
Nominal resistance value	6 kΩ (0°C)
Lead wire	Heat-resisting vinyl chloride wire
Lead wire length	500 mm
Lead wire heat resisting temperature	-20 to 105°C
Color code	Black
Accuracy	Within 2°C

Outline diagram (unit: mm)

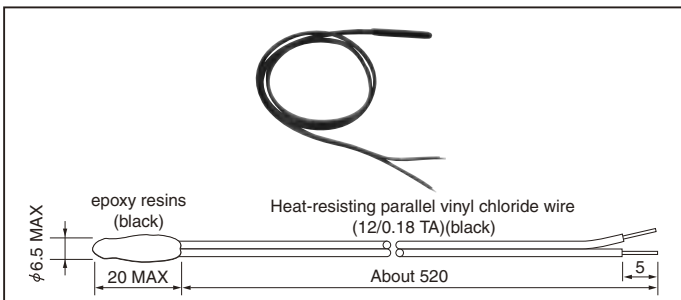

Connection diagram

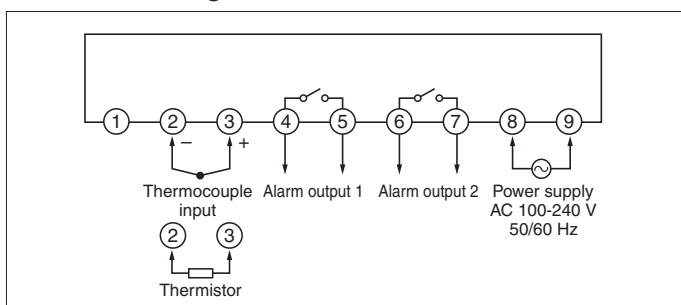

Outline diagram (unit:mm)

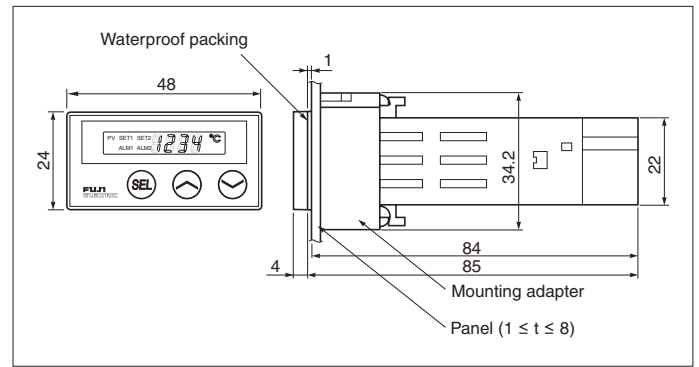

Panel cutout

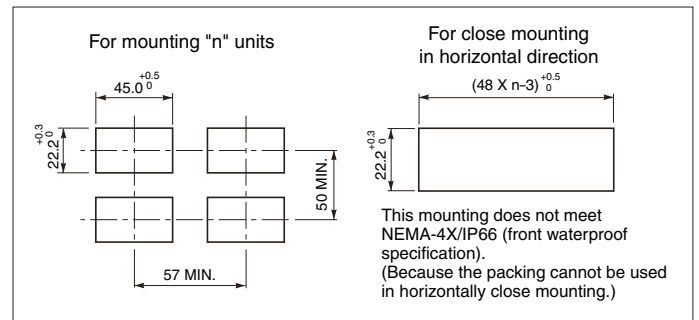

DIN rail mounting adapter (option)

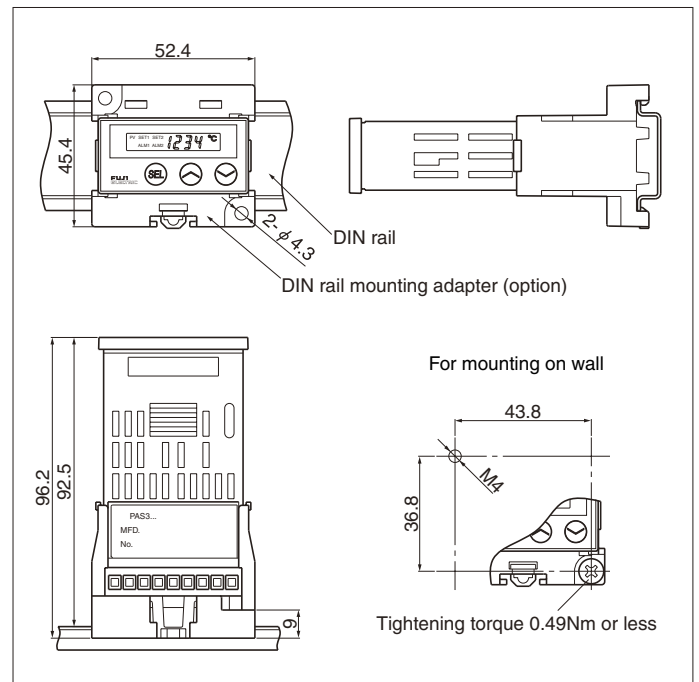







Usable wiring materials

- Wire (TYPE: Single wire)
Gauge: AWG28 (0.1 mm²) to AWG16 (1.25 mm²)
Strip-off length: 5 to 6 mm
- Bar terminal
Dimension of strip-off conductor section: 2 x 1.5 mm or smaller
Length of strip-off conductor section: 5 to 6 mm

List of temperature controllers

PX Series

Classification		3-key type with large display					Digital thermostat	
Type		PXR3	PXR4	PXR7	PXR5	PXR9	PAS3	
Front view (size mm)	Standard type	_____					_____	
	Waterproof type	 PXR3 (48X24)	 PXR4 (48X48)	 PXR7 (72X72)	 PXR5 (48X96)	 PXR9 (96X96)	 PAS3 (48X24)	
Input signal	Pt100	●					—	
	J thermocouple	●					●	
	K thermocouple	●					●	
	R thermocouple	●					●	
	B thermocouple	●					—	
	S thermocouple	●					—	
	T thermocouple	●					●	
	E thermocouple	●					●	
	N thermocouple	●					—	
	PL II thermocouple	●					—	
	1 to 5V DC	●					—	
	4 to 20mA DC	● (With resistor)					—	
Output signal	Relay	●					●	
	For SSR/SSC drive	●					—	
	4 to 20mA DC	●					—	
Control method	ON-OFF	●					●	
	PID	●					—	
	Auto tuning PID	●					—	
	Fuzzy	●					—	
	Self-tuning	●					—	
	Heating/cooling control	●					—	
Indicating accuracy	±0.5% FS ±1digit ±1°C					±3°C		
Communicating function (RS-485)	●					—		
Re-transmission output in 4 to 20 mA DC	●					—		
Timer function	●					—		
Digital input	●					—		
Ramp soak function	● (8 ramp/soak)					—		
Alarm output	●					●		
Heater burnout alarm (current output unavailable)	● (Unavailable for PXR3)					—		
Power supply voltage	100 to 240 V AC, 50/60 Hz or 24 V AC/DC					100 to 240V AC		
Front waterproof structure	●					●		

PX Series

	3-key type with PV/SV selective display	3-key type with PV/SV independent display	3-key type with PV/SV independent display	8-key type with PV/SV selective display	8-key type with PV/SV independent display	Classification
	PXV4	PXW4	PXW7	PXZ4	PXZ7	Type
	PXV4 (48X48)	PXW4 (48X48)	PXW7 (72X72)	PXZ4 (48X48)	PXZ7 (72X72)	Standard type
	PXV4 (48X48)	PXW4 (48X48)	PXW7 (72X72)	PXZ4 (48X48)	PXZ7 (72X72)	Waterproof type
	●	●		●		Pt100
	●	●		●		J thermocouple
	●	●		●		K thermocouple
	●	●		●		R thermocouple
	●	●		●		B thermocouple
	●	●		●		S thermocouple
	●	●		●		T thermocouple
	●	●		●		E thermocouple
	●	●		●		N thermocouple
	●	●		●		PL II thermocouple
	●	●		●		1 to 5V DC
	● (With resistor)	● (With resistor)		● (With resistor)		4 to 20mA DC
	●	●		●		Relay
	●	●		●		For SSR/SSC drive
	●	●		●		4 to 20mA DC
	●	●		●		ON-OFF
	●	●		●		PID
	●	●		●		Auto tuning PID
	●	●		●		Fuzzy
	—	—		—		Self-tuning
	—	—	●	—	●	Heating/cooling control
	±0.5% FS ±1digit ±1°C	±0.5% FS ±1digit ±1°C		±0.5% FS ±1digit ±1°C		Indicating accuracy
	—	—		—		Communicating function (RS-485)
	—	—		—		Re-transmission output in 4 to 20 mA DC
	—	—		—		Timer function
	—	—		—		Digital input
	● (4 ramp/soak)	● (4 ramp/soak)		● (4 ramp/soak)		Ramp soak function
	●	●		●		Alarm output
	—	—	●	—	●	Heater burnout alarm (current output unavailable)
	100 to 240 V AC, 50/60 Hz or 24 V AC/DC	100 to 240 V AC, 50/60 Hz or 24 V AC/DC				Power supply voltage
	●	●		●		Front waterproof structure

Front view (size mm)

Input signal

Output signal

Control method

SPECIAL ATTENTION NEEDED for all Micro Controller X series products

(Please read carefully the following instructions.)



Over-temperature Protection

Any control system design should take into account that any part of the system has the potential to fail.

For temperature control systems, continued heating should be considered the most dangerous condition, and the machine should be designed to automatically stop heating if unregulated due to the failure of the control unit or for any other reason.

The following are the most likely causes of unwanted continued heating:

- 1) Controller failure with heating output constantly on
- 2) Disengagement of the temperature sensor from the system
- 3) A short circuit in the thermocouple wiring
- 4) A valve or switch contact point outside the system is locked to keep the heat switched on.

In any application where physical injury or destruction of equipment might occur, we recommend the installation of independent safety equipment, with a separate temperature sensor, to disable the heating circuit in case of overheating.

The controller alarm signal is not designed to function as a protective measure in case of controller failure.

Fuji Electric Systems Co., Ltd.

Head Office

Gate City Ohsaki, East Tower,
11-2, Osaki 1-chome, Shinagawa-ku, Tokyo 141-0032, Japan
<http://www.fesys.co.jp/eng>

Instrumentation Div.

International Sales Dept.

No.1 , Fuji-machi, Hino-city, Tokyo,191-8502 Japan
Phone : 81-42-585-6201,6202
Fax : 81-42-585-6187
<http://www.fic-net.jp/eng>